

OPERATING AND INSTALLATION INSTRUCTIONS

SCAN-LINE GREEN 250



www.hetaheating.com

2024



EN

DANISH DESIGN . DANISH QUALITY . DANISH PRODUCTION

Congratulations on your new wood stove, we are confident that you will be more than satisfied with your new Heta stove. Especially if you follow the following advice and instructions.

The Green 250 pellet stove is approved under EN 16510.

These approvals are your guarantee as a consumer that the pellet stove meets a number of specifications and requirements which confirm that the stove is made of high-quality materials, that it is economical to use, and it is not harmful to the environment.

Please read these instructions for use carefully prior to installation and operation to avoid personal injury or damage to building parts or the product itself.

The above declared values apply to all variants of the Green 250.

Operating Instructions Contents

	Before installation.....	3
1.	Operating instructions.....	5
	Before using	5
	Filling of wood pellets	5
	First firing	5
	Lighting.....	5
	Manual pellet feeding.....	5
	Wood pellets	5
	Display.....	6
	Menu structure	6
	Menu overview	7
	Timer setting	12
	Settings	13
	Safety systems.....	13
2.	Cleaning and Service	13
	Daily Clening	13
	Monthly cleaning	14
	Semi annually / Annually	14
	Service interval	14
	Vermiculitestone.....	15
	Ash cleaning.....	16
	Cleaning interval.....	17
	Troubleshooting	17
	Chimney fire	18
	Stove data table EN 16510	18
	Adjustment of the combustion air	19
	Error codes and descriptions.....	20
	Wood pellets	21
	Parts	22
	Garantee.....	23
3.	Installation Instructions	24

Heta A/S

Jupitervej 22,
DK-7620 Lemvig

Phone: +45 9663 0600
E-mail: heta@heta.dk

Copyright © 2014
Heta is a registered
trademark of Heta A/S

Printed in Denmark
Subject to printing errors
and changes.

11.02.2026
0037-1795 Version 1.9

BEFORE INSTALLATION

Heta stoves are quality products, therefore, your first impression is very important! We have a good logistics network, which transports Heta products with great care for our dealers. Nevertheless, when in transport or handling, damage of the often-heavy stoves can occur. It is important that upon receipt check your Heta product completely and report any damage or defects to your dealer.

The packaging must be disposed of as follows: Wood, plastic and cardboard you can drop off at your local recycling center.

Mounting the display

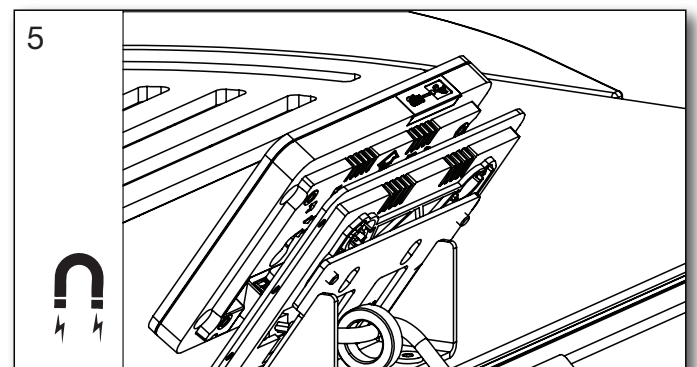
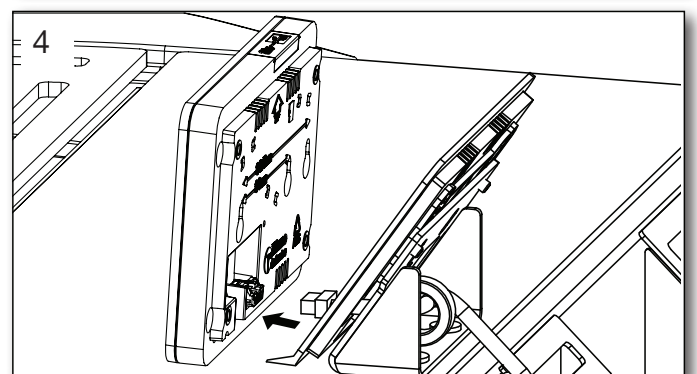
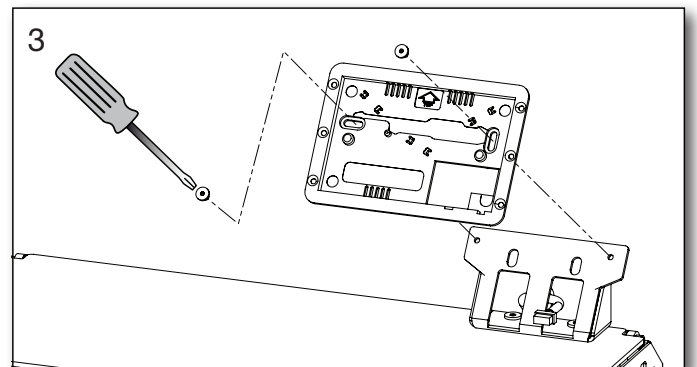
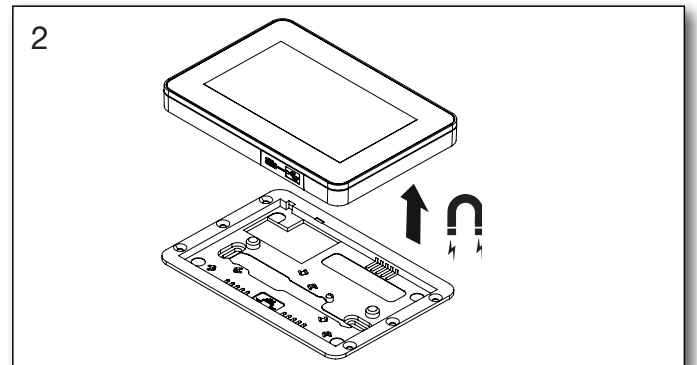
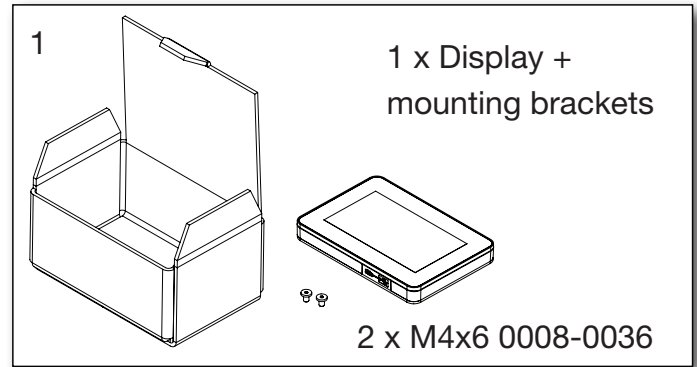

Unpacking the stove

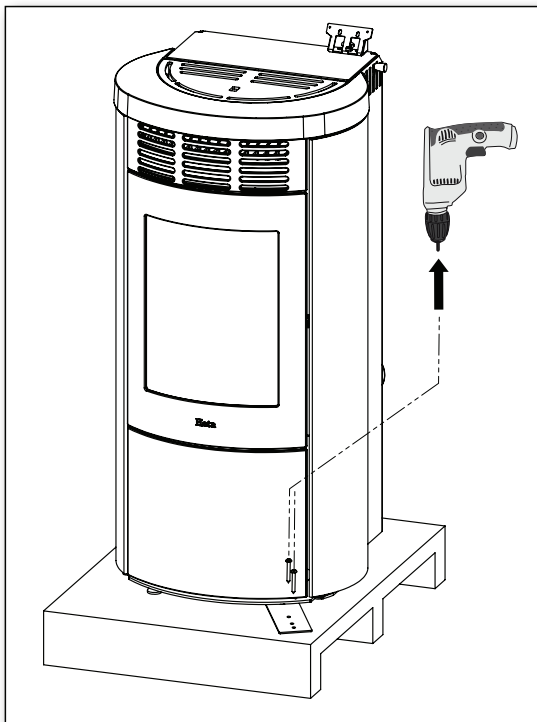

Moving the stove

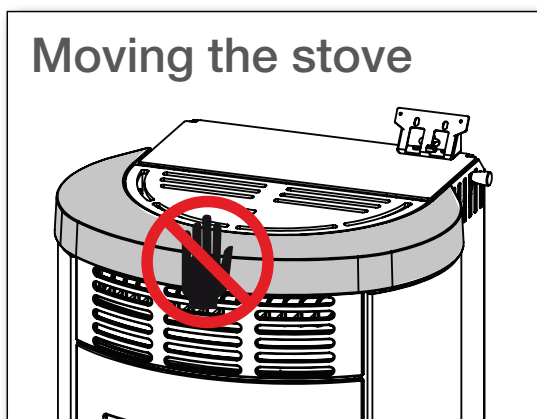

With your new wood stove you should find the following:

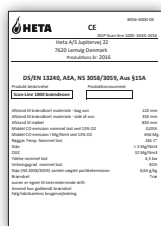
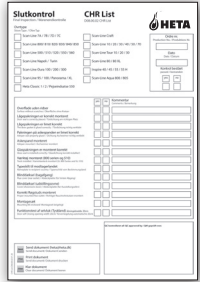
<p>Operating / Instruction manual</p>	
<p>Data plate</p>	
<p>CHR list</p>	

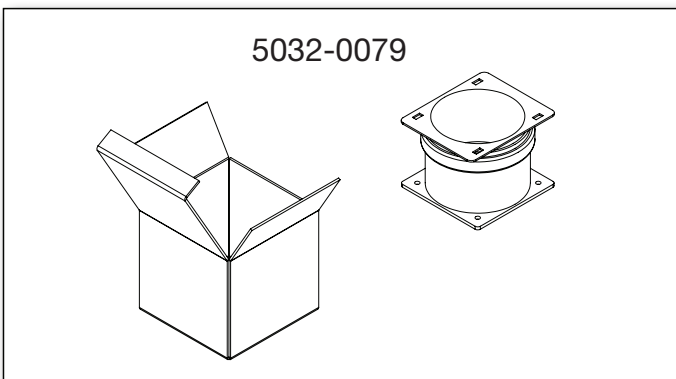

Required tools are not supplied.

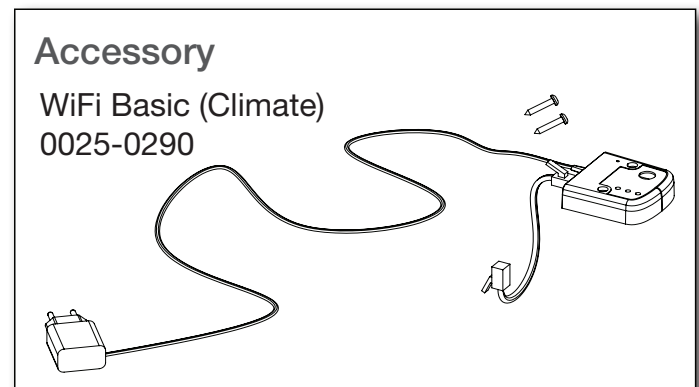
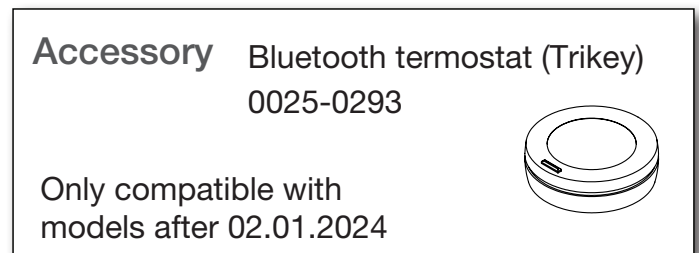
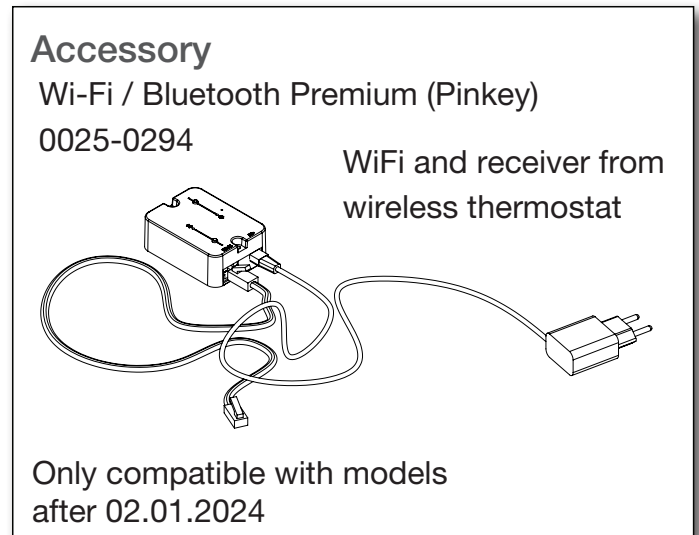
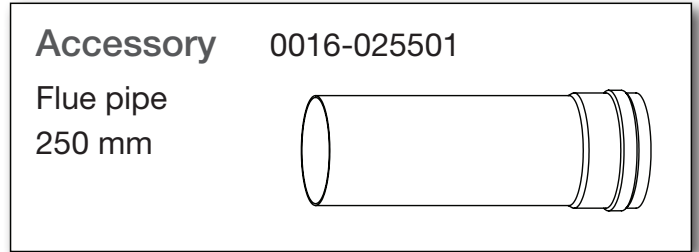

1. OPERATING INSTRUCTIONS

Before using

Before using the pellet stove, make sure that the installation requirements have been complied with. See page 24.

Filling of wood pellets

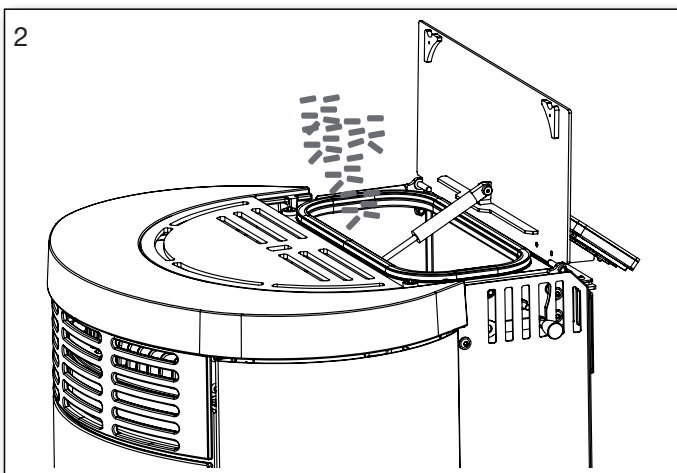
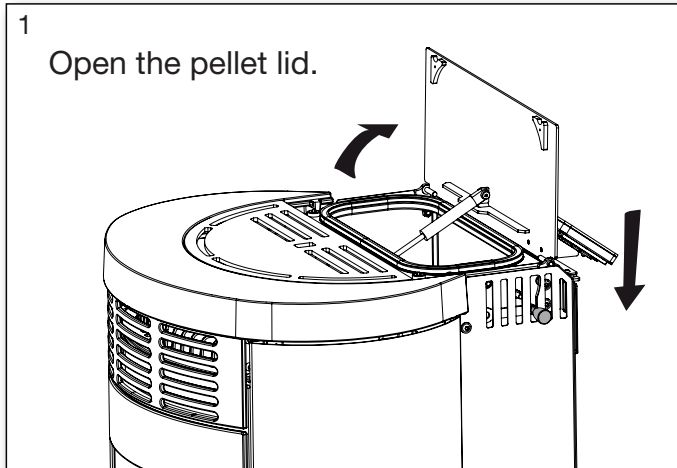

The bag of wood pellets must not be placed on the rubber seal when filling pellets in the tank.

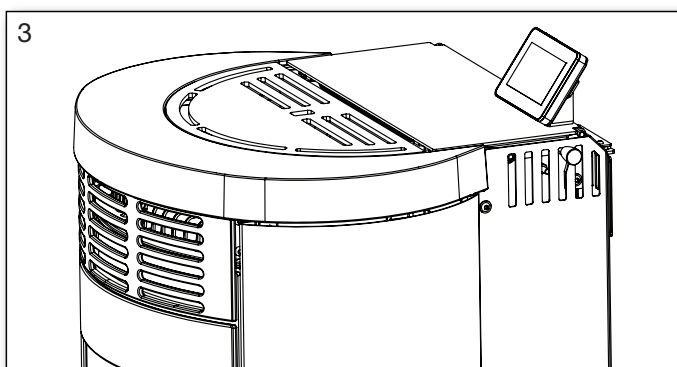

First firing

The stove paint is fully cured from the factory, but a minor unpleasant odour could still arise.



Lighting the stove

1. Check that the burn pot is in place in the frame. See page 14.
2. Roll out the room temperature sensor which is located on the back of the stove. Make sure that it does not come into contact with cold or hot surfaces.
3. Connect the stove to the mains using the supplied cable.
4. Set the desired settings using the display. See page 6.
5. Feed the pellets through as mentioned below.
6. Start the stove. See page 7.

Manual pellet feeding

Before starting your stove for the first time or if it has run out of wood pellets, the pellet feeder may be completely empty and therefore ignition may fail. To avoid this, on the display you can manually fill the pellet feeder before starting the stove.

Follow these steps to enable pill feeding:

Press  and then select .

Activate manual pill feed by sliding the button to the right. When the bottom of the burn pot is covered with wood pellets, the pellet feed is deactivated again and the burn pot is emptied of pellets to ensure that the ignition sequence is performed correctly.



Important

**The burn pot must be empty
Of wood pellets before start-up.**



**Never open the stove door while
the stove is in operation. When
the oven is switched on, all sur-
faces and glasses are extremely
hot and should only be handled
using the appropriate protection.**

Wood pellets

Only burn wood pellets in the pellet stove, Heta recommends 6 mm wood pellets.

Important information regarding wood pellets for your Heta pellet stove

It makes a difference in what type of wood pellets you use in your Heta pellet stove, as the quality is very important for the stove's combustion and the accumulation of soot in the smoke channels, as well as the ability to keep the burn pot free of buildup.

Heta recommends using 6 mm pellets with a maximum length of 30 mm and a moisture content of maximum 10% of the weight, which complies with the ENplus quality A1 standard. We have experienced that some dark pellets or pellet types that do not comply with the standard can have a high content of waste products that can cause the above-mentioned problems.

We recommend that you use light pellets without glues and bark, and at the same time it is important that the pellets are relatively the same length, as this affects the amount of pellets fed, and thus consistent combustion.

Menu structure

Main menu 1

Time and date: 11:24 | Mon 14 Apr 2019

Error code: Er.01

Room temperature: 21°C

Set temperature: 24°C

OFF

On/Off | Settings | Customization | Info | Chrono

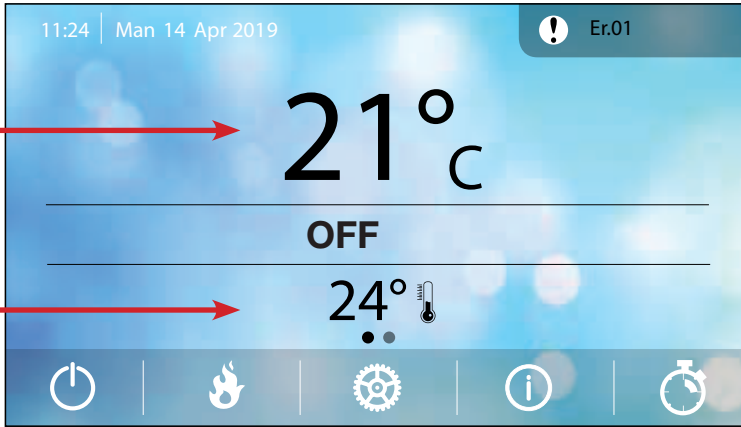

Status

By swiping down from the top of the display, you can see the combustion state and the current combustion effect.

Power P3

Timer

22°C

OFF

24°C

On/Off | Settings | Customization | Info | Chrono

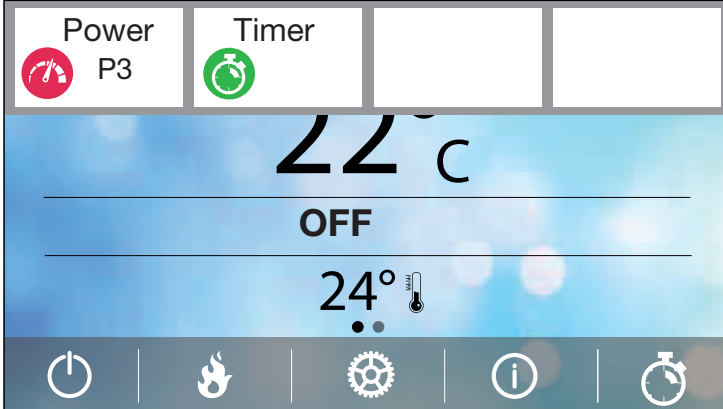

* Off / Daily / Weekly / Monthly

Display



Avoid water or other liquids coming into contact with the electronics, which may be destroyed and result in technical failures or malfunction and be dangerous to life.

Transparent protective film

It is recommended that you remove the protective film before using the Display to guarantee the best performance of the sensitive (touch) surface.

Menu overview

1



Slide to turn on/off.

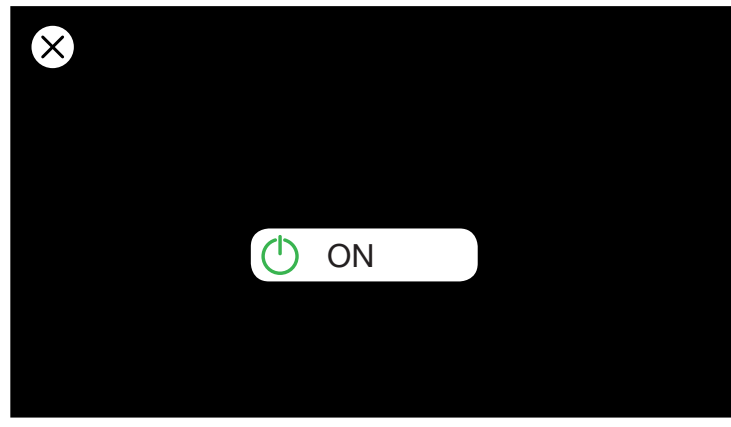

2

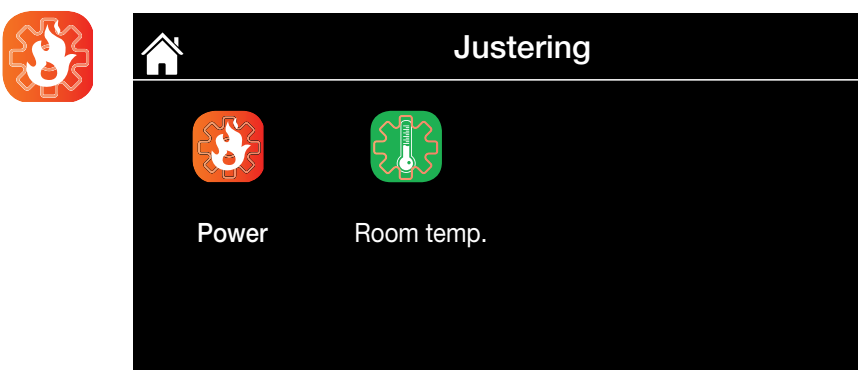

Power Room temp.



Power level P3

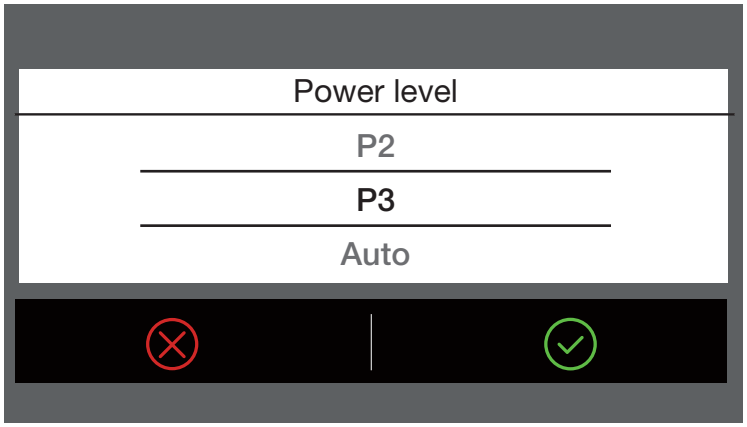

Power level

P2

P3

Auto

✗ | ✓

3



To select room temperature

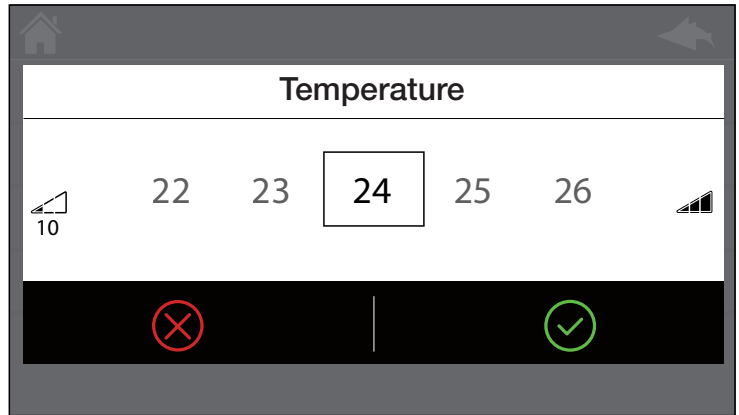
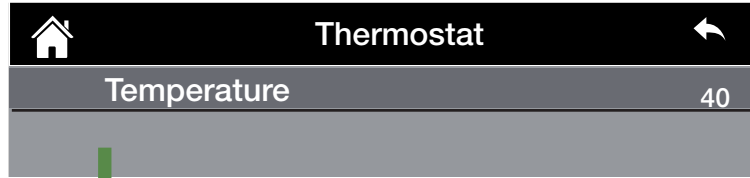

4

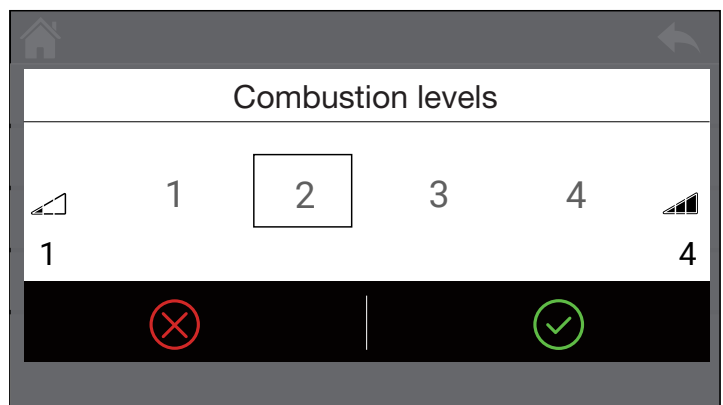
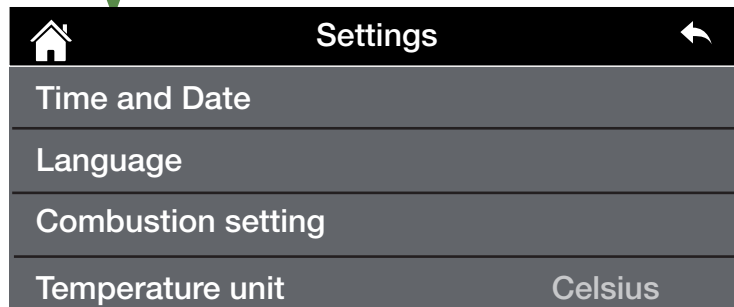
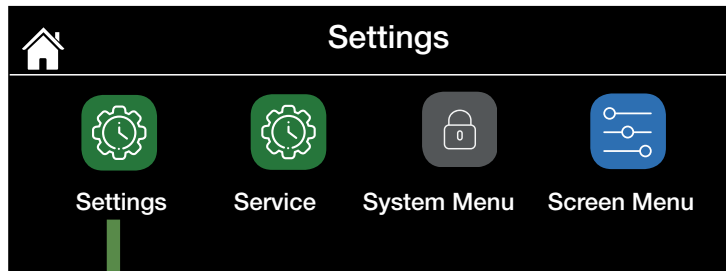

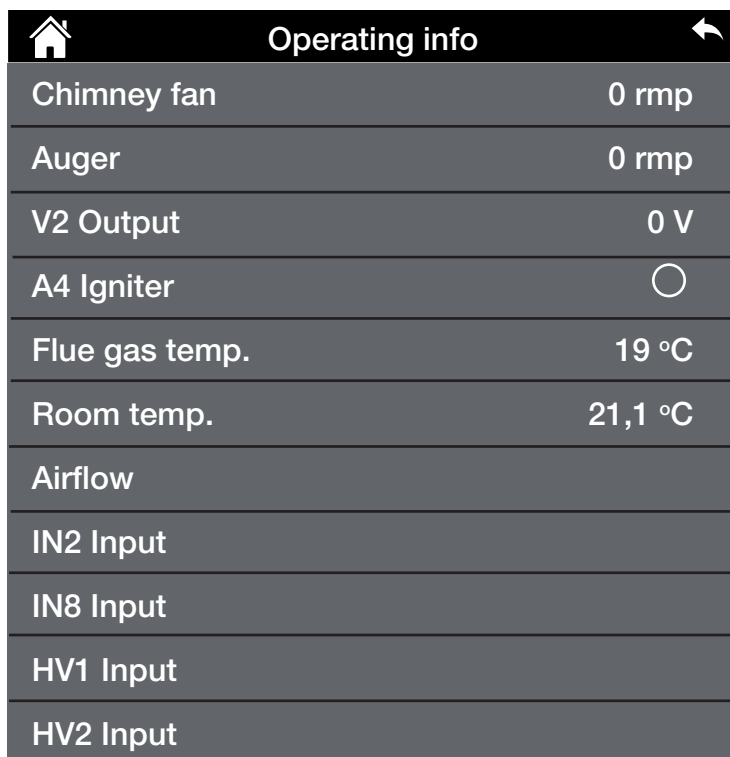
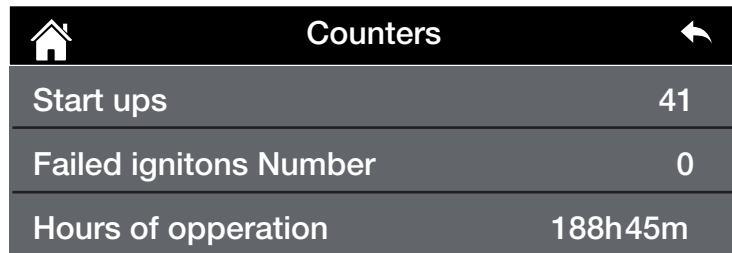
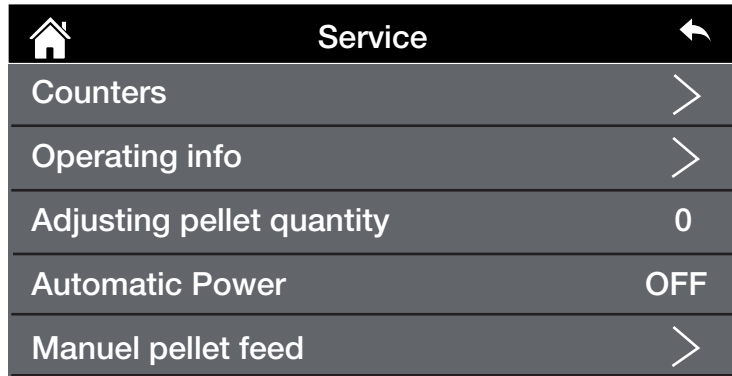
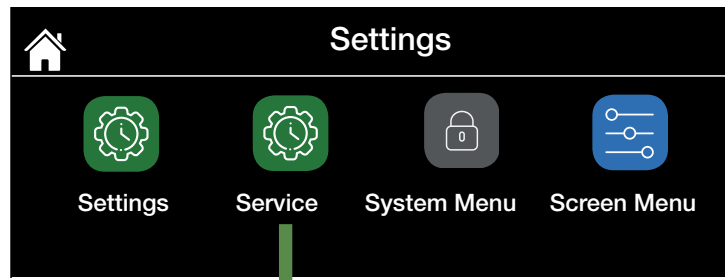

6

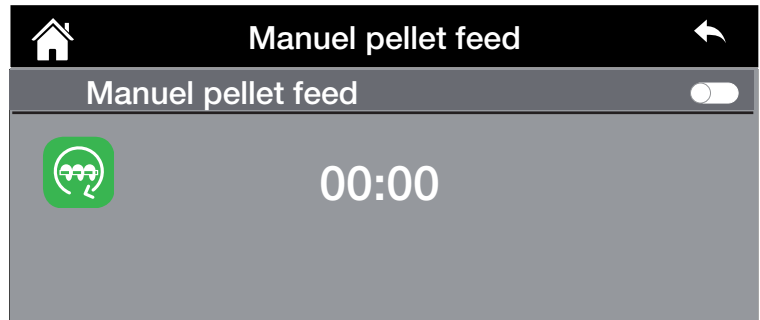
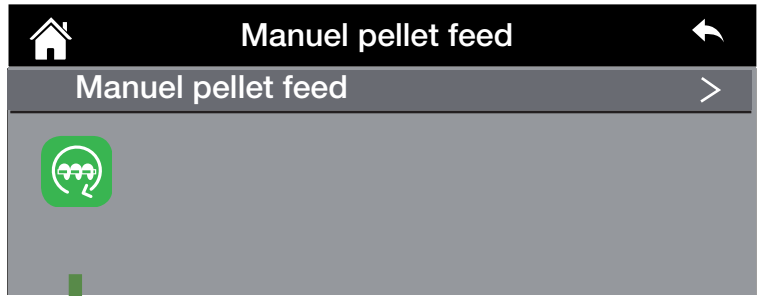
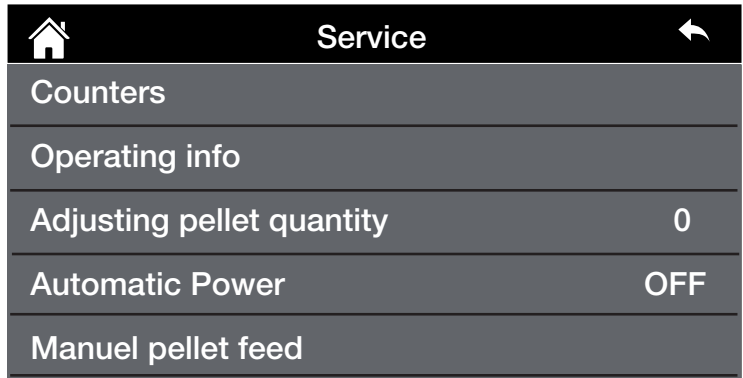

Important
The burn pot must be empty for wood pellets before start-up.
See page 5.

7

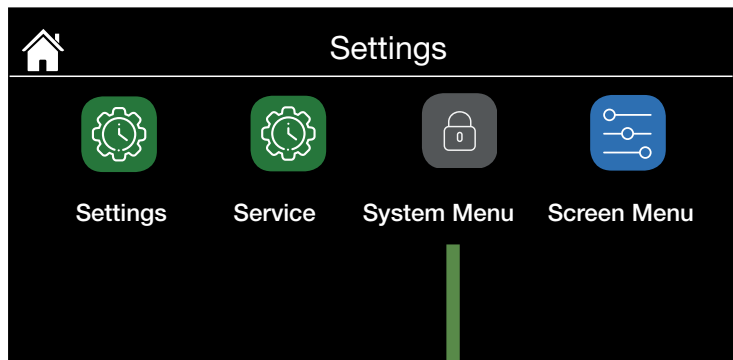

Only for service technician

8

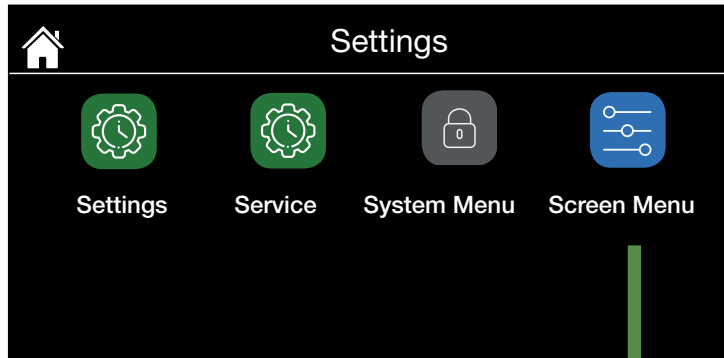

9

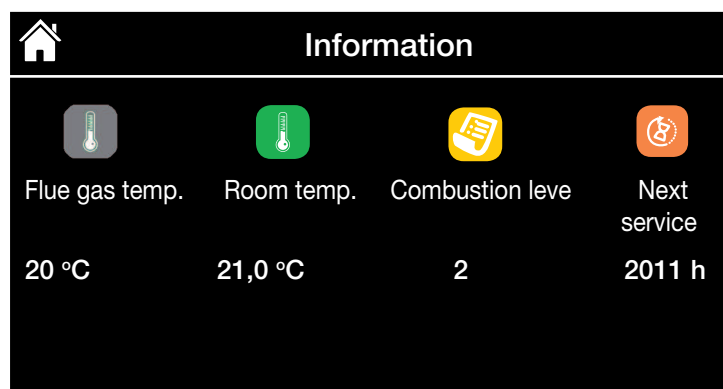

Timer setting



Possible menus:

Daily

In DAILY, you can change three different time settings for each day of the week.

Weekly

In WEEKLY, you can change three different times for all days.

Weekdays/Weekend

IN WEEKDAYS/WEEKEND you can change three different times for weekdays and other times for only Saturdays and Sundays.

Daily

First, select the day for the desired program. Then tap one of the three possible programs

Start/Stop

Select the start and stop time for the program

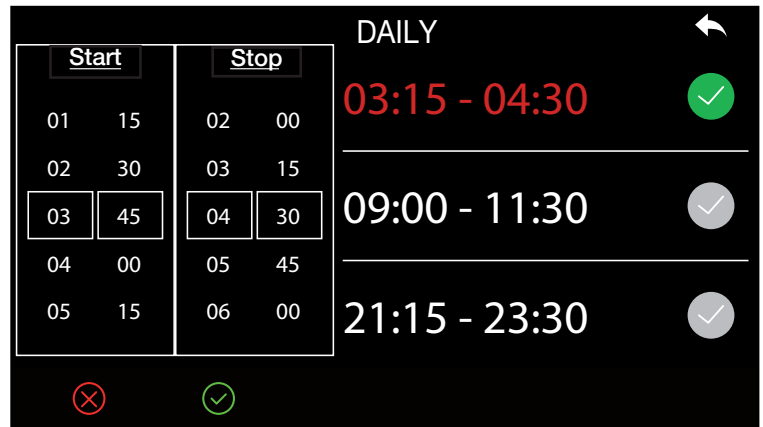
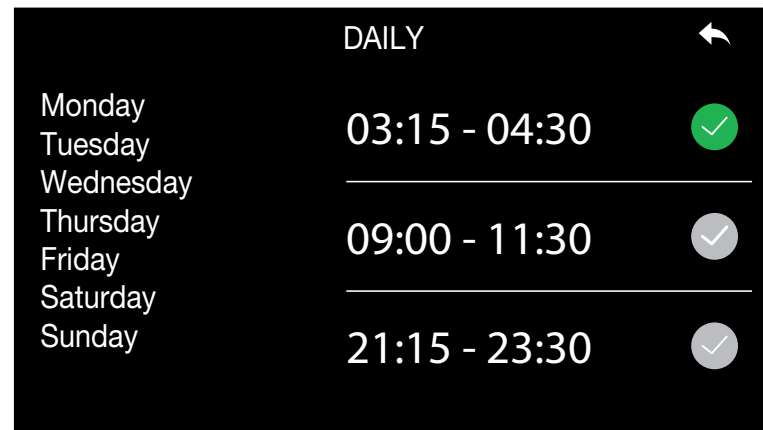
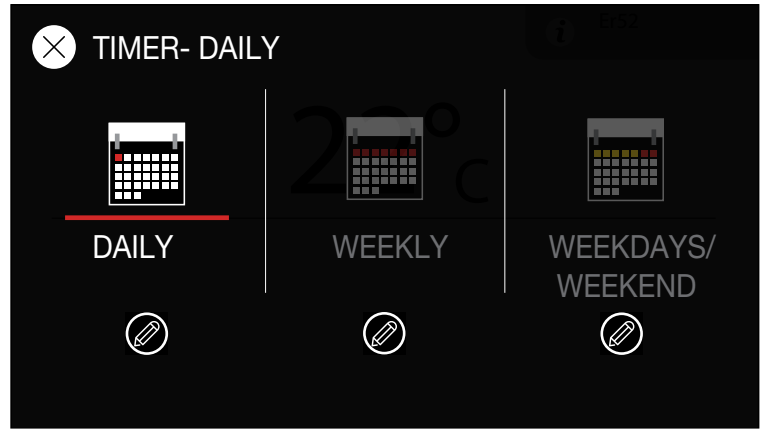

Settings

1. Select the desired language.
2. Set the correct date and time.

Change of output/heat

On the display, you can switch between three different heat levels.

Press the icon  to access the main menu.

Press the icon  and select Combust.

Can be set to automatic or manual.
In automatic mode, the system selects the combustion effect.

In manual mode, you select the desired effect yourself.

Manually set the desired heat level from 1 to 3 or select automatic mode.

Setting the desired temperature

On the display, you can set the desired room temperature.

Press  and select  where you can change the desired room temperature.

Confirm  or cancel the change .

Switch on/off manually on the display

Press  and slide to the right on the display. This applies both to on and off and when resetting any error messages. See page 7.

Automatic with timer

On the display you can set daily, weekly and weekend sequences.

To change or set a TIMER program, press .

Then choose either daily, weekly or weekday/weekend. See example on page 12.

Safety systems

The pellet stove is equipped with advanced safety systems to prevent damage to the stove or the residential environment which could occur as a result of one of the elements breaking or through a fault in the chimney.

If irregularities occur, the pellet supply will cease immediately.

2. Cleaning and Service

Daily Cleaning

Cleaning the burn pot

A clean burn pot is essential to ensure the pellet stove operates correctly and without problems. During operation, baked on ash deposits will develop and must be regularly removed, as these impede correct combustion.

Correct daily cleaning of the stove will ensure optimal combustion, excellent performance and the avoidance of operational failures which may ultimately require assistance from a technician to return the stove to working order.

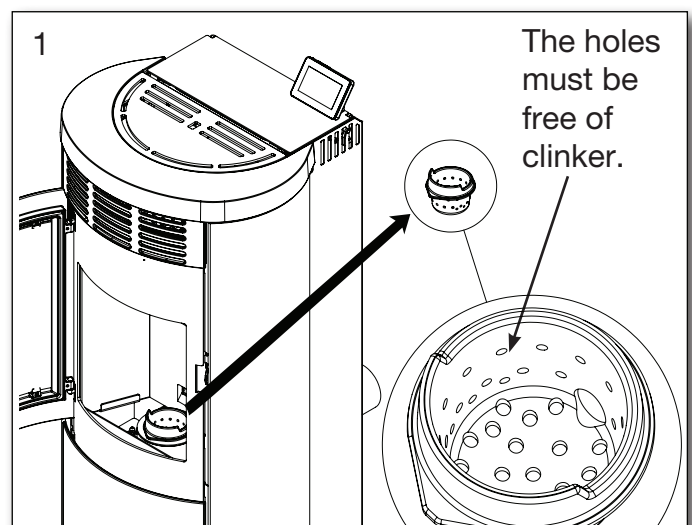

Inserting the burn pot after cleaning.

Fig. 2

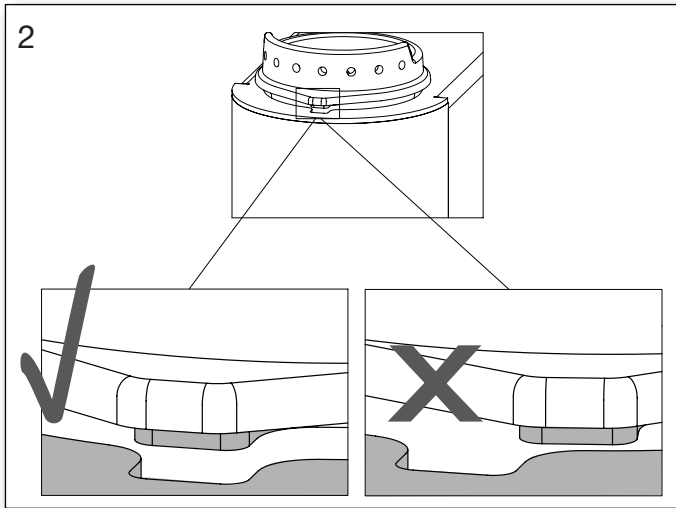

Cleaning the glass

Clean the glass whenever necessary. Depending on the pellet quality and heat level used (a low heat level leads to more dirt/deposits), deposits will eventually form on the glass. These can be removed using paper or a cloth and glass cleaning agent.

Cleaning the display

The display can be cleaned gently using a dry cloth. Grease stains are removed by drying the unit with a cloth and a mild detergent.

Monthly cleaning

Emptying the combustion chamber

The combustion chamber must be vacuumed approximately once a month depending on how often the stove is in operation and the quality of the pellets. The stove requires light but regular cleaning to ensure stable operation.



Note: This is done when both the stove and the ashes are cold.

Glass door seal and gaskets

It is important that the glass door seal, the ash pan gasket and pellet tank cover seals tightly, as the stove requires underpressure in the combustion chamber for correct operation. The glass seals must be replaced if worn, or glued in place using ceramic glue if loose.

Ask your dealer if you need assistance.

Emptying/Cleaning of the pellet tank (*)

Pellet tank should be emptied and vacuumed for dust and pellet remains at least monthly.

Semi annually / Annually

Internal flue pipe and chimney fan (*)

The stove's internal flue pipe must be kept free from ash and soot. Clean the pipe with a cleaning brush and vacuum the ash room. Remove the chimney fan and clean any ash or soot off the housing and blades.

Cleaning the Pressostat: (*)

The pressostat is connected to the chimney fan by a silicone hose. Clean the silicone hose if dirty using water and soap (ensure it is completely dry before reinstalling). Apply suction to the pressostat inlet and listen to hear if it clicks.

Cleaning the convection fan (*)

Check that the convection fan turns easily by turning it with your fingers. Clean off dust and any other dirt, for example using a soft brush.

Cleaning the flue gas channel (*)

Clean the flue with a cleaning brush. Vacuum and clean any soot and ash from the inspection hole, which is located behind the ash chamber.

Items marked (*)

should only be made by an authorized dealer, however, there may be special circumstances that cause the frequency of cleaning these components to be more frequent than indicated here if the environment where the oven is installed requires this. This can be done by the customer by agreement.

Service interval

There is a built-in service counter.

The status of this SERVICE COUNTER can be found in the information menu.

This SERVICE COUNTER counts down from 2200 hours. An alarm will sound when this time has expired. This alarm will continue to flash until an authorised service technician has serviced the stove and reset the service counter.

The stove can still be used in this period.



Service interval 2200 operating hours or at least once a year.

Vermiculitestone

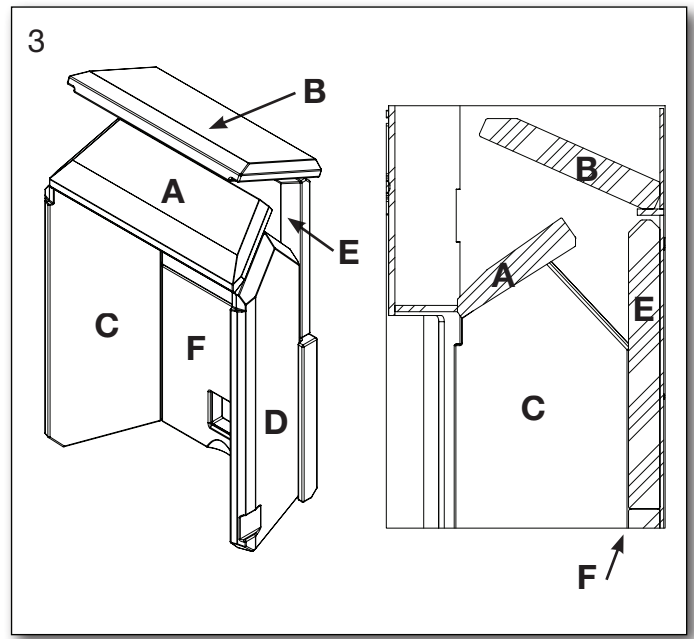
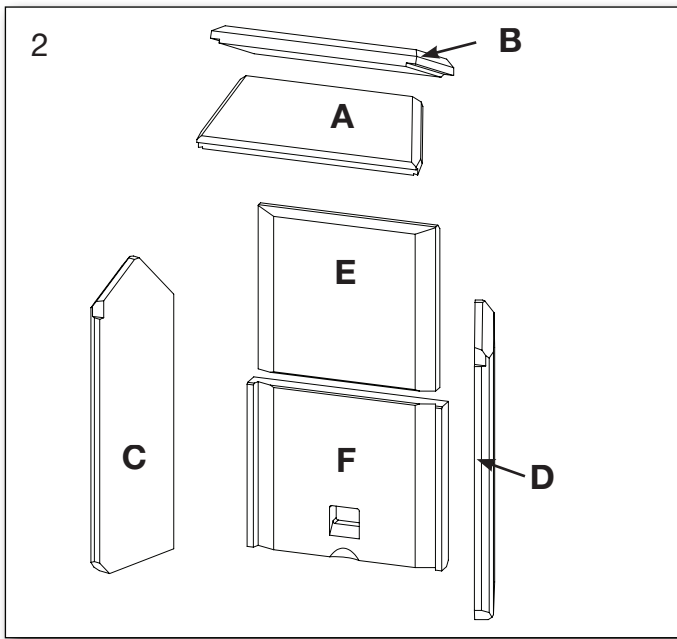

Smoke baffles **A/B** must be removed monthly to remove ash. See page 14.

To remove all the stones, first remove **A**, then **C**, **D**, **E**, **F** and finally **B**. Fig. 4.

The stones are put back in reverse order.

NOTE:



That the vermiculite stones are a porous material and must be treated accordingly.
That the stones are not covered by the guarantee.

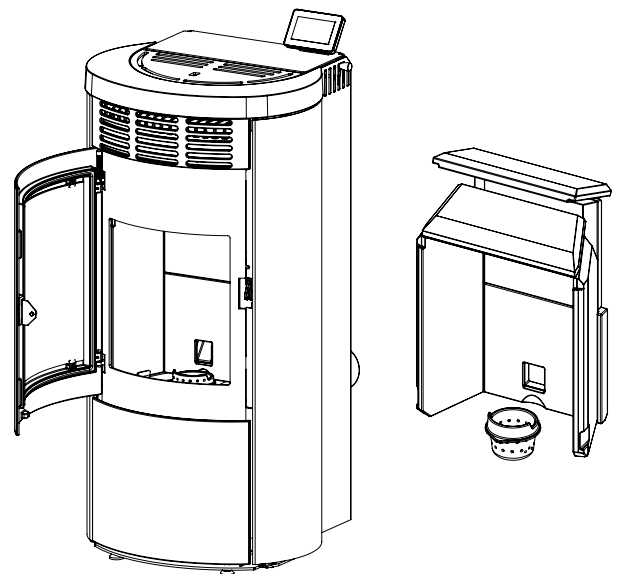

Order for removal of the vermiculite.

See fig. 4

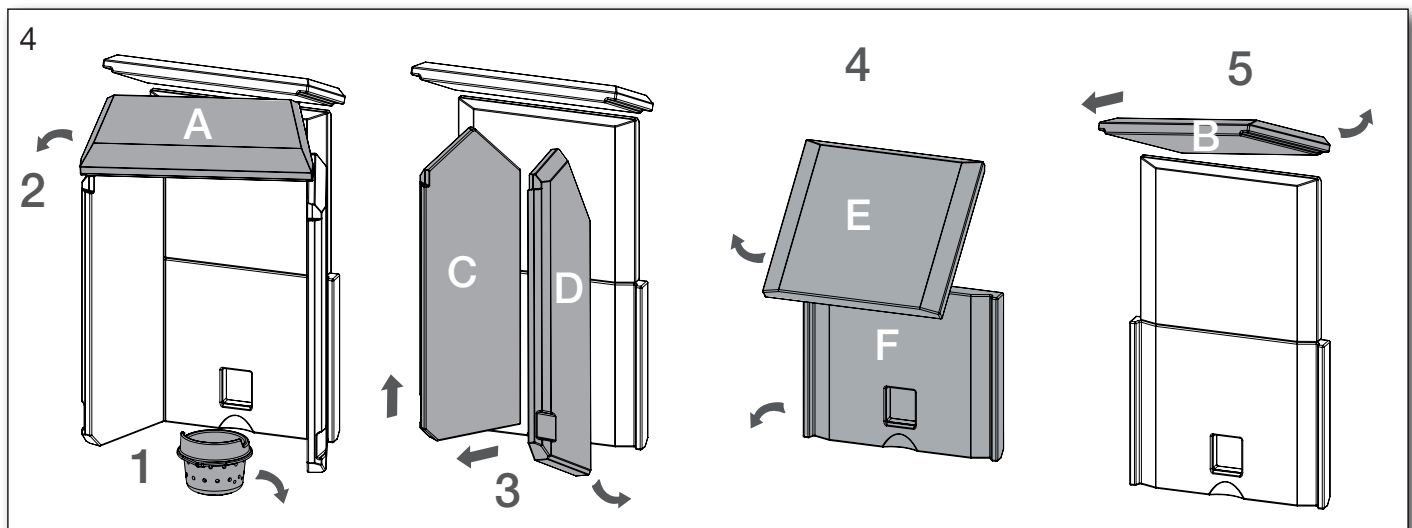

Ash cleaning - must be monthly

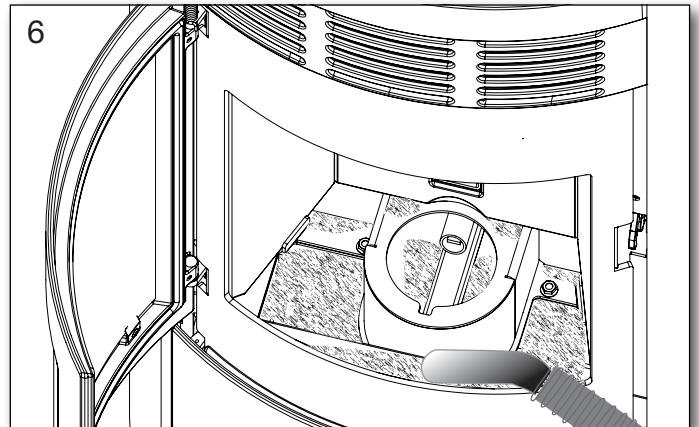
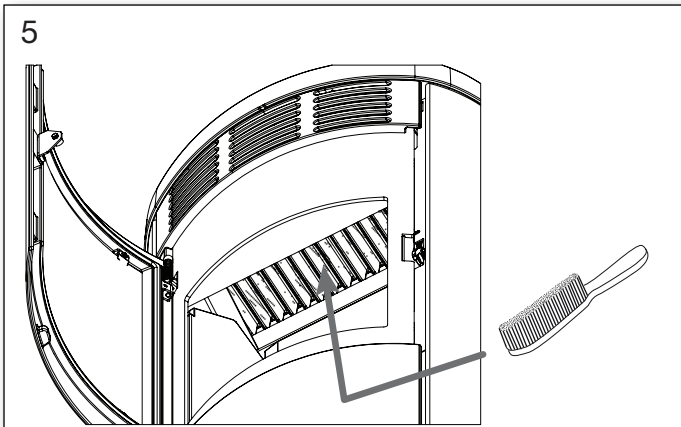
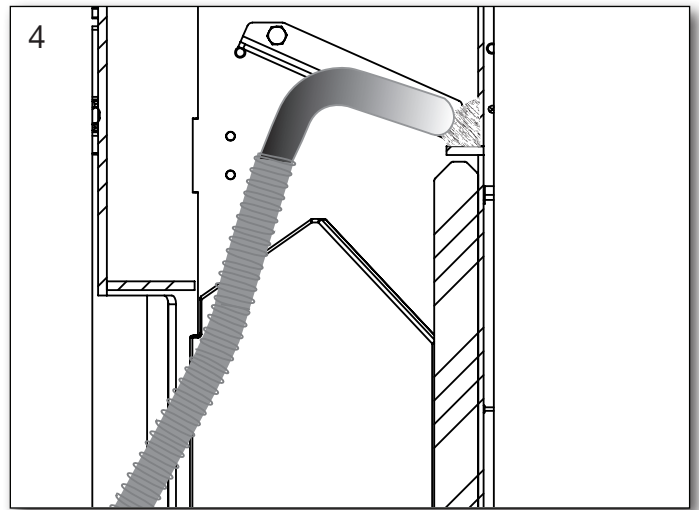
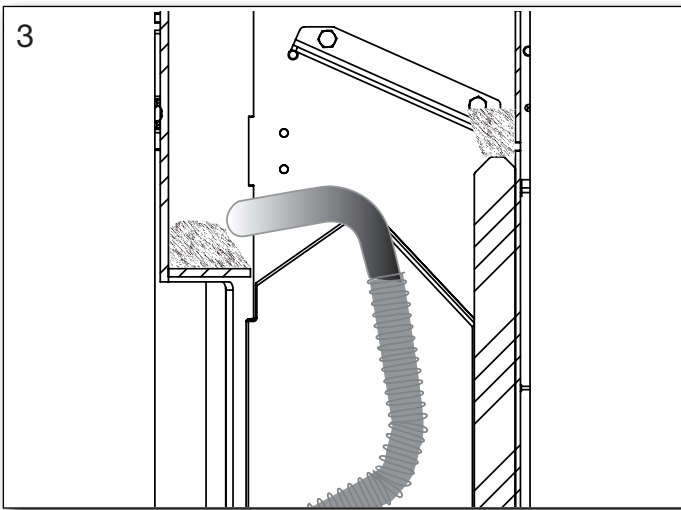
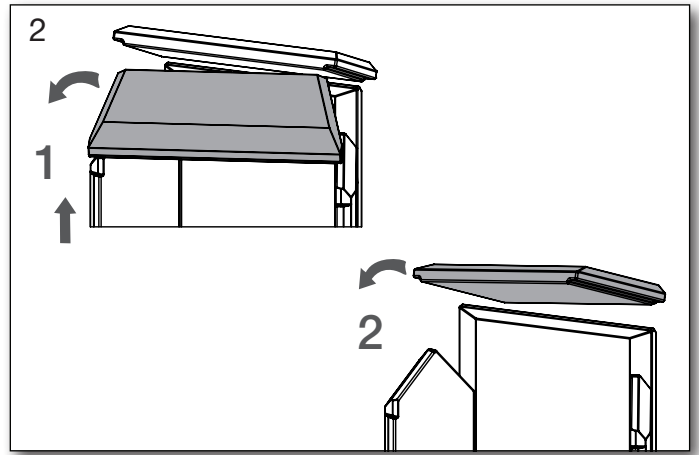
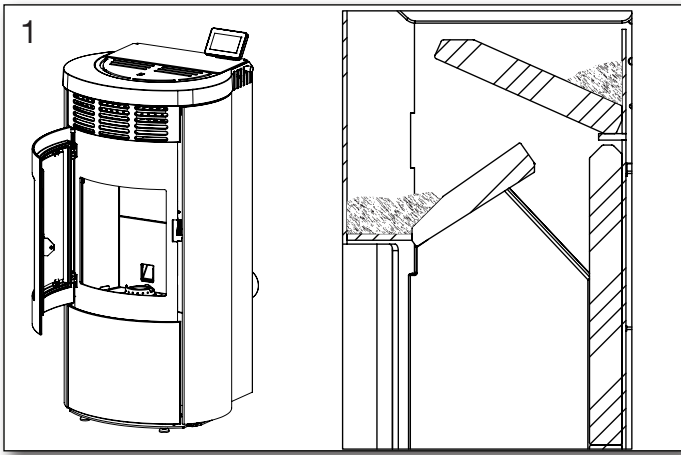

Ash cleaning - semi-annually or annually

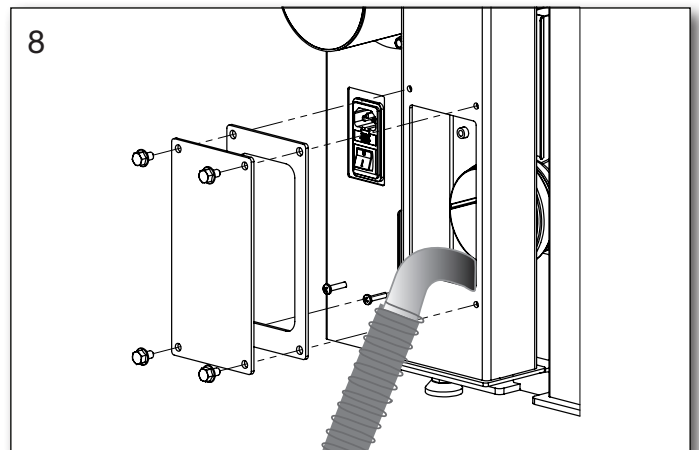
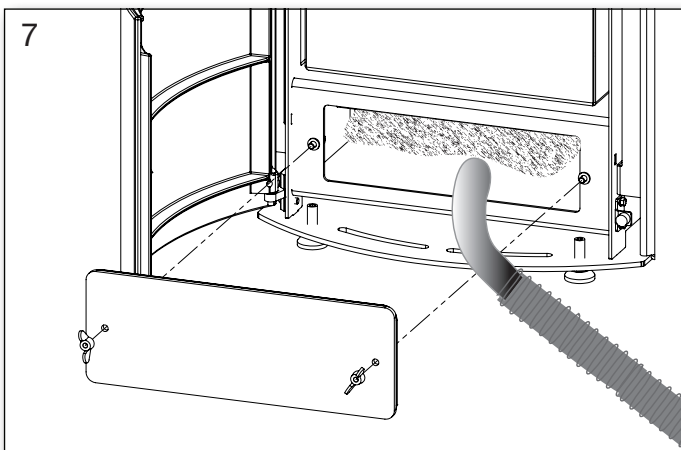

Cleaning interval

Parts / Frequency	Daily	Weekly	Monthly	Semi-/annually
Burn pot	X			
Combustion chamber			X	
Glass		X		
Baffle plate			X	
Vermiculitestone			X	
Seals and gaskets			X	
Pellet tank			X	X
Flue gas channel and chimney fan (*)				X
Pressure switch (*)				X
Convection fan (*)				X
Internal flue pipe (*)				X

Points marked with an asterisk (*) should only be carried out by an authorised dealer.



If the directions and cleaning schedule in this cleaning manual are not observed the warranty will become void.

Troubleshooting

Alarms and errors

An alarm will trigger an error screen display and the problem needs to be resolved as soon as possible.

In the event of an alarm, the stove may still be partially usable. However, it will not be fully functional.

Contact a professional as soon as possible.

In the event of an error message, the error screen will continue to flash and the problem must be rectified without delay.

In the event of an error message, the stove will not function correctly. A professional MUST be contacted.

Most alarms and errors have a code that helps to localise the problem.

See page 20 for error codes.

Intro to Troubleshooting

Compared to a conventional wood-burning stove, a pellet stove features a lot more mechanical and electronic systems. As a result, a number of problems may arise that can have a negative influence on both ignition and combustion.

It is a good idea to check through these troubleshooting guidelines before calling a service technician and/or submitting a complaint.

Troubleshooting

Before ignition, check that:

- a) The iron lid in the top to the pellet tank seal tightly.
- b) The burn pot is sitting tightly against the lower section, and that there is no ash or pellet residue between the burn pot and the pipe in which it is fitted.
- c) The seal on the door to the combustion chamber is intact, and all edges of the door sit tightly against the chamber.
- d) The stove has been thoroughly cleaned as described in the cleaning section of this guide.

If there are faults in one or more of the areas mentioned above, rectify the fault and then test run the stove. See page 19.

Detailed explanations of sections **a** through **d**.

Section a:

If the seal between these parts is not tight, unwanted air will be drawn through the pellet tank and into the stove. This air will not contribute to the combustion process – rather it will reduce the volume of air used for combustion. The effect on/diminishing of the combustion process will be greater the fewer pellets are left in the tank, because the air resistance through the tank falls in step with the quantity of pellets in it.

Section b:

It is important that the burn pot is correctly positioned and forms a tight seal with the stove, because the combustion air will otherwise flow around the pot. See page 11 fig. 2. This will result in poorer combustion and diminish the ef-

fect of the cleaning function. The diminishing effect on the combustion will increase proportionately to the soiling of the burn pot.

Sections c:

It is essential to keep the seal on the door tight because even a small leak will have serious consequences on the combustion. If the ash pan is even slightly open, the stove will hardly be able to burn any fuel at all, and will quickly become dirty.

Sections d: See page 13-14.

Chimney fire

In case of a chimney fire.
Call the fire department.

Stove data table in accordance with en 16510 testing

Tested as a freestanding oven and with uninsulated flue

Stove type Pellet stove	Nominal fluegas temperature C°	Flue mm	Consumption per hour kg	Draft min. mbar	Nominal output tested kW	Actual efficiency %	Distance to flammable materials mm				Stove weight kg
							at the side	rear the stove	Corner distance 45°	to furnitures	
Green 250	87	ø80	1,88	0,10	8,8	95	150	80	70	650	*

Average temperature in the flue pipe connector:
~ 109°C.
Pos. A, B and C fig. 1.

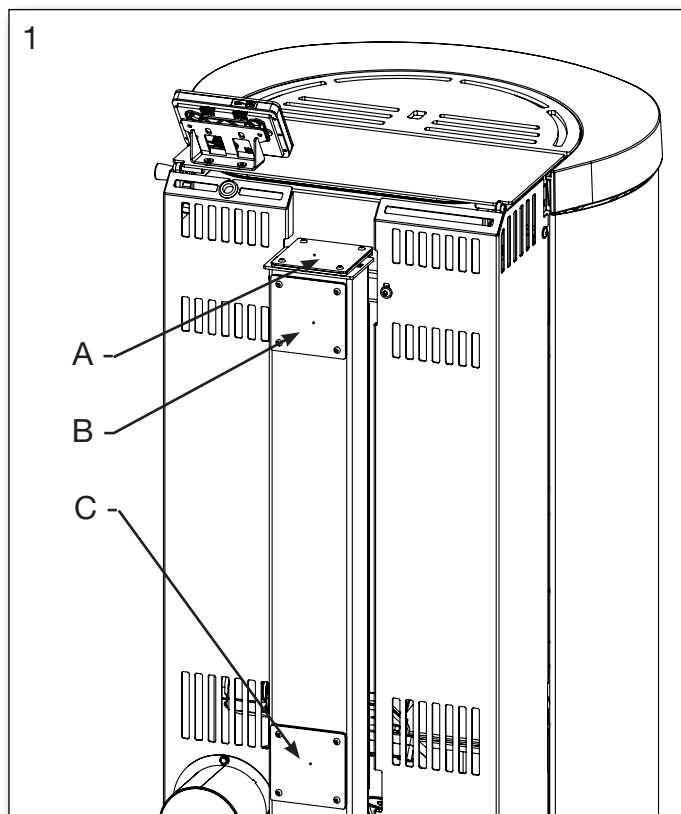

* Weight table Scan-Line Green 250

Steel	160 kg
Complete soapstone	242 kg
Top soapstone	167 kg
Top blackwood	166 kg
Complete blackwood	228 kg
Complete limestone	235 kg
Top limestone	167 kg

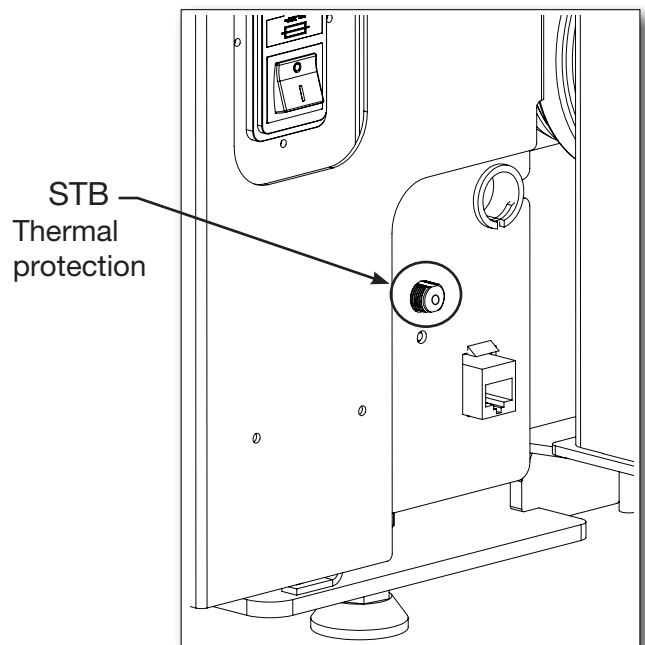

Adjustment of the combustion air

Before starting, see page 5 the section on ignition and manual pellet feeding. Start the pellet stove in power 2, choose between basic steps 1,2,3 or 4.

During this process, it is important to check that there is sufficient combustion airflow to the stove. The sign of a successful ignition process is that the flames are pale yellow after 25 minutes of operation – the flames should also remain pale yellow if you turn the heat down. However, when adjusting to a lower level, there will be a ‘conversion period’ given that the airflow is reduced and fewer pellets are delivered to the stove. This process will normally last for a few minutes, when the flames may burn dark yellow or orange until optimal combustion is re-established (pale yellow flames)..

Is the stove not burning cleanly?

If the stove settings are correct but the combu-

stion produces dark flames, several factors may be having an influence. Pellet type and chimney will be the most significant factors, and the following section describes the relevant solutions.

The stove’s basic settings are based on a pure, pale pellet and a chimney with a draught of 10 pascals. If a different type of pellet is used (e.g. a dark, heavier pellet) or if there is insufficient draught in the chimney, it may be necessary to increase the combustion airflow.

If this is not sufficient to achieve the combustion desired, an approved service technician/dealer can increase the airflow even more using the hidden parameters in the control programme.

If the stove receives too much air – possibly as a result of a chimney with excessive draught – it is likewise possible to reduce the airflow in the combustion process.



Too much air

Ignition failure

Burn pot fills with pellets without being ignited.

Pellets jumps like ‘popcorn’.



Too little air

Black tarry soot on the glass

Soot causes black back stone.

Big chunks of slag in the burn pot.



Right amount of air

The back stone is clean and without colouring from soot.

Burn pot is clean.

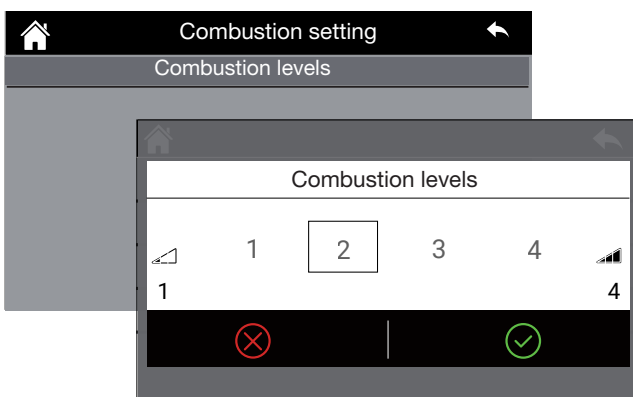

Combustion level 1:

Lowest air volume for the combustion air

Combustion level 4:

Maximum amount of air for the combustion air



Important

The burn pot must be empty for wood pellets before start-up. See page 5.

Error codes and descriptions

Error codes	Description of error code	Possible cause	Solution
Er01	STB is tripped or defective (voltage fault)	Mechanical circuit breaker if the pellet tank has been too hot with no visible faults in the pellet tank	STB can be activated again by pressing the safety switch behind the oven. If the problem persists, contact your dealer.
Er02	Pressure switch is tripped or defective	Chimney or flue stopped/ blocked	Check and clean if necessary.
Er03	Shut down due to insufficient flue gas temperature	Faulty start-up or too small flame in start-up.	Check that the burner pot is clean and that the stove delivers pellets. Make sure that the smoke ducts of the stove are clean.
Er05	Shut down due to excessive flue gas temperature	Combustion temperature too high.	Contact the dealer for inspection and possibly stove adjustment.
Er07/Er08	Error on signal flue vacuum pump encoder	Fault on the smoke sensor speed sensor.	Contact dealer for visit.
Er12	Ignition error	Faulty start-up or too small flame in start-up or operation.	Check that the burn pot is clean and that the stove delivers pellets. Make sure that the smoke ducts of the oven are clean.
Er15	Power supply failure	The power has been turned off or a fault in the power supply internally in the oven.	If the error can not be deleted - contact dealer.
Er16	Motherboard error messages	Fault in the stove's internal communication.	Disconnect and reconnect the power the oven if it does not help - contact dealer.
Er17	DP flow adjustment error	Fault in air regulation in the stove.	If weather conditions are normal - contact dealer.
Er39	DP sensor error	Fault on air control sensor for the smoke extractor.	Contact dealer.
Er41	DP flow too low	Not enough suction (negative pressure in the stove).	Check the tightness of the oven gaskets. Make sure that the smoke ducts of the oven are clean.
Er42	DP flow too high	Too much suction (negative pressure in oven).	If there are normal weather conditions - check that the smoke extractor does not run at such a high speed that pellets are blown out of the burn pot.
Link error	Fault in the oven's internal communication network.	Fault in the oven's internal communication.	Disconnect and connect the power to the oven if it does not help - contact dealer.

Service call

Service	Perform service	The stove needs service.	Contact dealer.
----------------	-----------------	--------------------------	-----------------

Info messages

Door	The pellet cover is open	Pellet tank top is not closed	Check that the pellet tank top is closed / positioned correctly.
-------------	--------------------------	-------------------------------	--

Cleaning: The stove has a function that cleans the burn pot every 18 minutes to avoid clogging.

Wood pellets

Most people do not experience problems when they fire with wood pellets. Wood pellets are easy to use and modern pellet stoves are extremely user-friendly. Normally there is little need for repeated annual inspections, and you will quickly discover that the pellet stove takes care of itself most of the time.

Should you, however, experience problems with the pellet stove, you can almost always be certain that they are due either to the settings and/or the installation of the pellet stove or the quality of the wood pellets used. Using an inferior quality wood pellet will automatically lead to greater ash production, which can have a negative impact on the efficiency of the pellet stove.

EFFECTIVE CALORIFIC VALUE OF WOOD PELLETS

When determining the quality of your wood pellet, take a look at its effective calorific value. The effective calorific value is an expression of the amount of energy that a wood pellet can deliver and is determined by the content of water and ash in the wood. The best wood pellet contains a maximum of 0.4% ash and a maximum of 7% water. At these percentages, a wood pellet delivers 4.9 kWh/kg.

WOOD PELLET CHEMISTRY

Wood pellets are basically compressed wood which, when burned, produce energy that can be used to heat your home. However, as can be seen from the above, it is important that you pay attention to the content of the various components of the wood pellet and to how it behaves under the circumstances to which it is exposed when burned.

WATER CONTENT

Water is a natural part of wood. And, as previously mentioned, the content of water directly affects the efficient calorific value. When the wood pellet is burned, water evaporation occurs. If the water content is very high, it will negatively impact the energy level, just as you risk more ash build-up inside the chimney. However, water is a necessary component of the wood pellet, as moisture helps to ensure a durable pellet and prevent dust. Choose a moisture content of 6-8% for the best result.

ASH CONTENT

When you burn wood pellets, a residue will occur in the form of ash. Here, of course, you want

to select a wood pellet that produces as little ash as possible. There is a big difference in the amount of ash wood pellets produce. The best pellets produce as little as 0.3%, while standard pellets can produce as much as 5%. Bear in mind that a high effective calorific value and a low level of water result in the least ash content.

ASH MELTING POINT

It is very important to know the ash melting point when avoiding clinker build-up in the pellet stove. Clinker is what happens when the ash from the pellets clumps together and this process can reduce the efficiency of the pellet stove. Therefore, always pay attention to the ash melting point of the pellets and choose a product where the ash melting point is above 1,200°C.

DENSITY

The density of the wood pellet depends on how hard it is pressed together. The harder the compression, the smaller the pellet, which still produces the same amount of energy.

WOOD PELLET DURABILITY IS IMPORTANT

When you buy wood pellets, you will often buy large quantities at a time. Both because it is cheaper and because you need a lot of wood pellets to meet your energy requirements. It is therefore important that you think carefully about how to store the pellets.

Pellets with poor mechanical durability break during transport and can crumble. Here you must select a wood pellet that has a strength of 97.5%. The figure here means that after transport only 2.5% of the pellets will have been destroyed.

Also bear in mind that the pellets are sensitive to the elements. They must therefore always be stored using appropriate packaging. That way you can be sure that they remain free of mice, rats or other vermin. Protect them from moisture and store them indoors if possible.

Heta A/S recommends using Premium wood pellets from Heatlets.dk to get the most out of your pellet stove.

Parts Vermiculite and burn pot

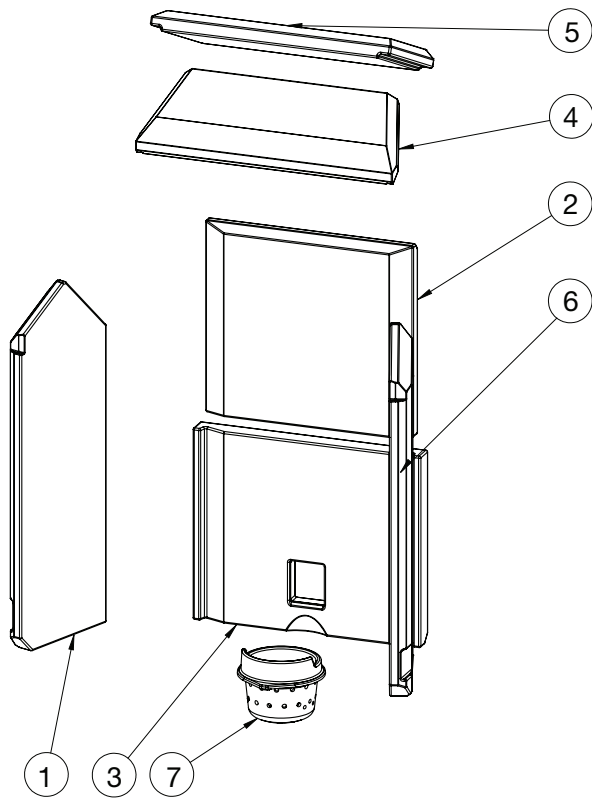

Pos.	No.	Name	Qty.
1	0023-024277	Vermiculite, side, left	1
2	0023-024279	Vermiculite, rear, top	1
3	0023-024280	Vermiculite, rear, bottom	1
4	0023-024281	Baffle, bottom	1
5	0023-024278	Baffle, top	1
6	0023-024415	Vermiculite, side, right	1
7	0023-023704	Burn pot	1

Parts

Gasket - Pellet lid

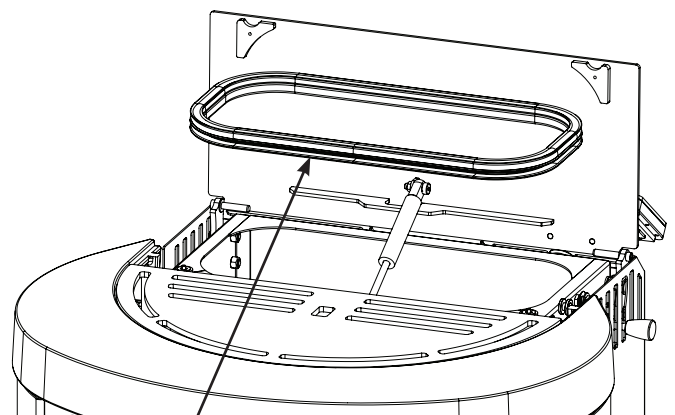

0023-024389 Gasket

Parts - Door

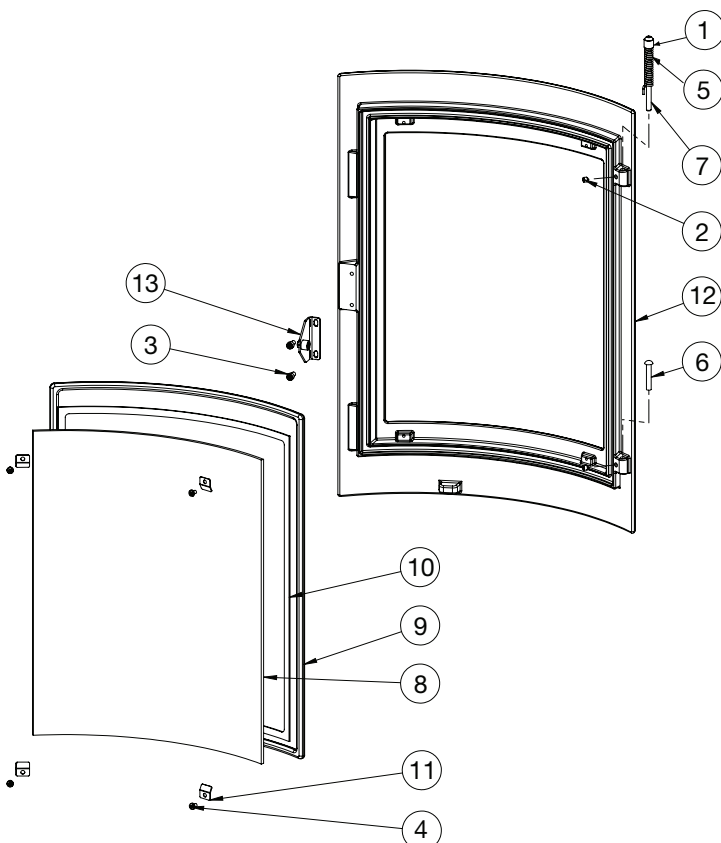

Pos.	No.	Name	Qty.
1	0008-0058	M6x8 Hexagon socket bottom head screw BN 19, Black	1
2	0008-1002	M6x6 Hexagon socket set screw BN 30, FZB	2
3	0008-2005	M5x10 Hexagon socket head screw BN 610, RF A2	2
4	0008-2304	M4x6 Hexalabular socket pan head screw BN 5687, RF A2	4
5	0008-9080	Spring 2x7 Indv. x 3 stg. x 17 v	1
6	0008-9082	6x35 Round head rivet BN 988	1
7	0016-0083	Shaft for automatic closing mechanisme	1
8	0021-0042	Glass	1
9	0023-3008	Glass gasket $\varnothing 12 \times 1,8 \text{ m}$	1
10	0023-3013	Glass gasket with adhesive 3x8 mm 1,8 m	1
11	1013-0432	Glass clips - small	4
12	1505-0077	Door	1
13	1513-0116	Close roller	1

Parts Gaskets

0016-024931
Chimney lid gasket



0016-025935
Gasket for
cleaning cover

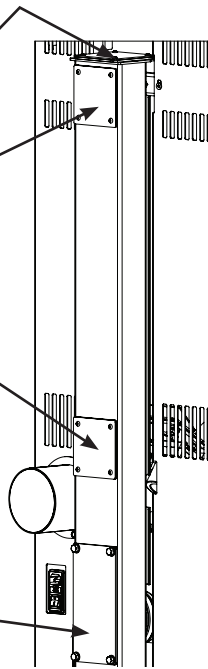

Guarantee

We would like to thank you for purchasing your Green 250 pellet stove. We recommend that you read:

- The instructions for installation, use and maintenance
- The warranty conditions specified below:

Heta wood-burning stoves are subjected to thorough quality inspections throughout the manufacturing process and before they leave the factory and are delivered to the dealer.

Therefore, the duration of the warranty is 5 years on this product, covering manufacturer's defects, 2 years on electronic components. In addition, there is a 3-month goodwill warranty, on gaskets, vermiculite and glass from the date of sale from the shop. Photos of the damaged parts must be sent for review.

The guarantee does not cover:

Wearing parts such as:

- Fireproof stones in the combustion chamber
 - Glass
 - Sealant tape
 - Glass rope
 - Stainless steel burn pot
- Any damage arising from inappropriate installation and/or treatment of the stove and/or customer errors.

- Damage caused by incorrect use.
- Freight costs in connection with repairs under the guarantee.
- Assembly / disassembly in connection with repairs under the guarantee.

Using pellets of poor quality or pellets made of materials other than pure wood can damage stove components. As a result, the warranty is considered null and void and the manufacturer's liability is forfeited.

Transport damage is not covered by the warranty. We therefore advise you to check the stove immediately on delivery and to inform the dealer immediately if damage is discovered. The manufacturer's warranty obligations are limited to those described above, and no claims can be made on the basis of a verbal request.

**When making a claim,
please state the invoice no.**

Warning



If unauthorised changes are made to your pellet stove and parts other than original spare parts are used, the guarantee will be considered null and void.

Installation Instructions

Contents

3.	Installation instructions	25
	General information.....	25
	Placement	25
	Safety information	25
	Liability	25
	Floor	25
	The chimney connection	26
	Chimney draft.....	26
	External air supply.....	26
	Installation	26
	Distance Provisions.....	27
	Disassembling soapstone before installation.....	28
	Installation of HETA-climate Wi-Fi	28
	Installation of external fresh air	29
	Stovedrawings/measurments	30
	EU Declaration of Conformity	31



Remember

The stove and chimney installation, must comply with local regulations, including those referring to national and European standards.

3. Installation instructions

General information

The Green 250 pellet stove must only be installed in residential environments.

The stove installation must be in accordance with national, European and possibly local regulations. You must follow local regulations with regard to installation of chimney and connection to the chimney. Be aware that it is always the owner himself who has responsibility for ensuring that applicable rules are complied with.

A modern pellet stove places heavy demands on the chimney due to the high efficiency. It may be necessary to enhance or even replace an old chimney.

The stove has fully automatic control, ensuring controlled combustion. The control system manages the ignition process, three heat levels and shutdown, ensuring that the stove functions correctly.

Placement

The position of the stove within the home will have a major impact on heat distribution. Before deciding where to place the stove, it is important to consider the following:

- a) The air supply for combustion must come from a ventilated room or an open outdoor area.
- b) Installation in a bedroom is not advised.
- c) The stove must be installed in a spacious and central location in the house to ensure the best heat distribution.

Safety information

The Green 250 pellet stove must be installed by a technician who has been trained by Heta A/S.

Please read these instructions regarding use and maintenance carefully before installing and lighting the stove! If you need further information, please contact the dealer from whom you purchased the stove.

NOTE



The stove has extra protection in line with power regulations, and must have an earthed electrical connection.

Liability

By providing these instructions, Heta A/S disclaims all liability, both personal and statutory, for any accidents that may arise due to failure – either fully or in part – to observe the instructions enclosed herein.

Heta A/S disclaims all liability in relation to incorrect use of the stove, abnormal usage by the customer, unauthorised replacement and/or repair, or the use of non-original spare parts for this model.

The manufacturer disclaims all liability, both personal and statutory, direct and indirect, attributable to:

- Inadequate maintenance
- Failure to observe the instructions in this manual
- Failure to observe safety directions
- Irregular installation with failure to observe applicable standards in the destination country
- Installation carried out by unqualified or untrained personnel
- Replacement or repair not authorised by the manufacturer
- Use of non-original spare parts
- Extraordinary events



If you have any questions concerning your pellet stove, Heta strongly recommends that you contact your dealer immediately.

Floor

You must ensure that the floor can support the weight of the stove and a top-mounted steel chimney.

In front of the pellet stove, the substrate must consist of non-combustible material, for ex. Steel/glass plate, stone or tile floor. The size of the non-combustible surface must follow the applicable national and local regulations.

The chimney connection

The flue gas system is dependent on a slight underpressure in the combustion chamber and it is very important that the chimney exhausts to outside air and not to an enclosed or semi-enclosed room such as a garage, corridor, attic or anywhere else where the flue gases could become concentrated.

The chimney must always be installed in accordance with national and regional regulations.

If local regulations permit, two contained stoves can be connected to the same chimney. However, you must abide by local regulations regarding the distance between the two connections.

The stove must never be connected to a chimney that is linked to a gas fire stove.

Chimney draft

Operation of the Green 250 pellet stove is partly independent of the chimney draught, as the flue gas vacuum pump assists in removing smoke from the combustion chamber. However, if there is a strong chimney draught over 20 pascals, we recommend a draught stabiliser be installed. Otherwise the chimney will overrun the flue vacuum pump, resulting in too much combustion. The stove operates best with a chimney draught of 8-12 pascals (used for testing/approval) in a chimney with a diameter of 80-150 mm

Flue gas mass flow is 6 g/sec.

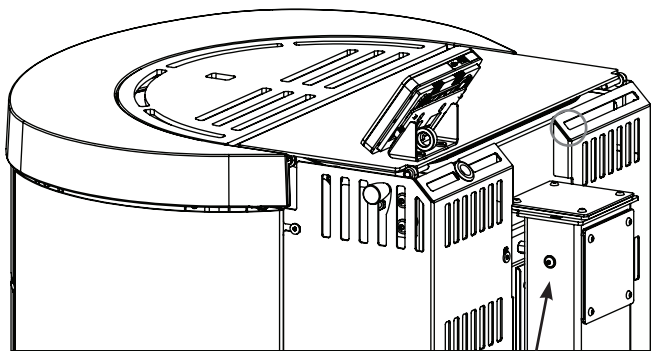

The chimney draft can be measured here

External air supply (Accessory)

In hermetically closed environments with little air replacement it can be difficult to supply enough air for the combustion and it may be necessary to supply extra air to the room.

The pelletstove receives the total combustion air

flow from the room where it is installed, but you have the possibility to add external combustion air flow. A sealed air intake can be connected to the stove's air intake connector.

Installation

Either remove the cover **A/B/C** depending on the outlet you want to use.

Mount the selected outlet **F / G** on the free space on the chimney which is visible after the removal of either **A/B/C**.

Cover **D** is for the cleaning of the chimney.

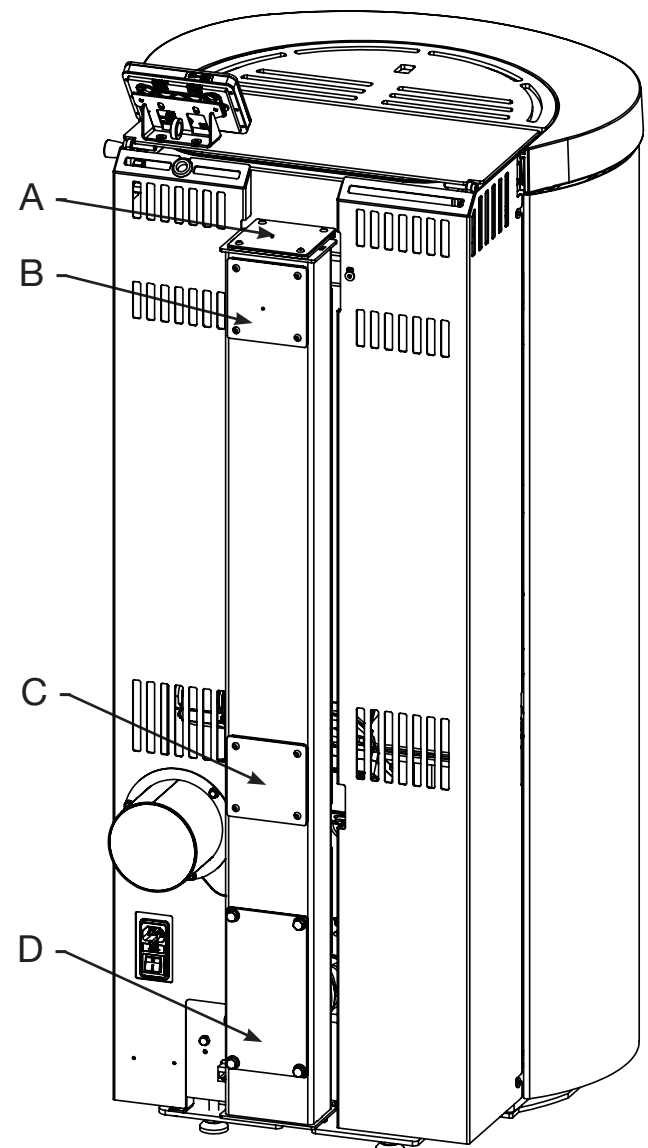
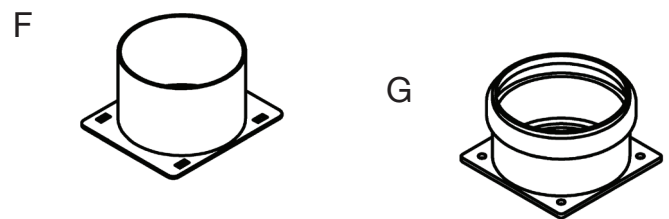

Distance Provisions

There is a difference between installation next to flammable wall or non-flammable wall. If the wall is made of non-flammable material, the stove in principle may be placed flush against it.

We recommend a minimum of 5 cm to facilitate air circulation around the stove.

If in doubt, contact your chimney sweep for advice and guidance.

Distance to combustible

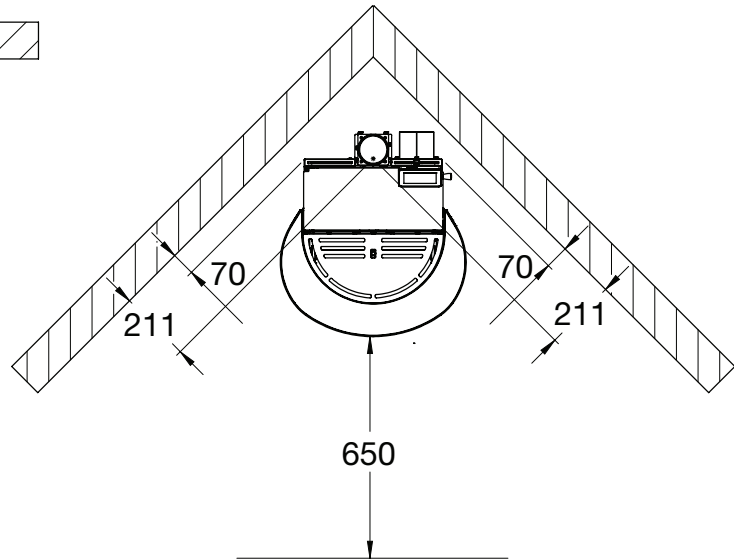
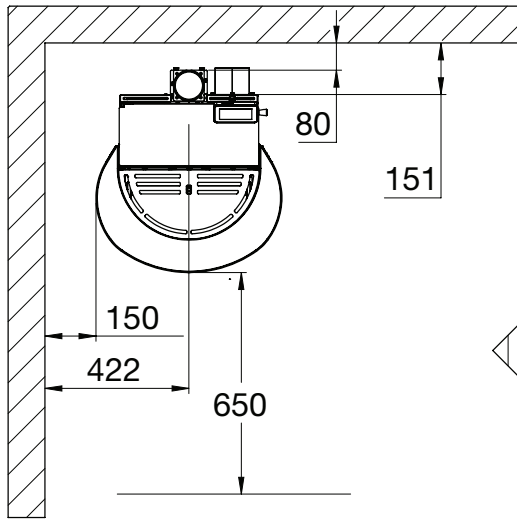

Do not remove the adjusting screws



The dimensions are the minimum dimensions, unless otherwise stated.

Minimum 250 mm uninsulated flue 0016-025501 is accessory

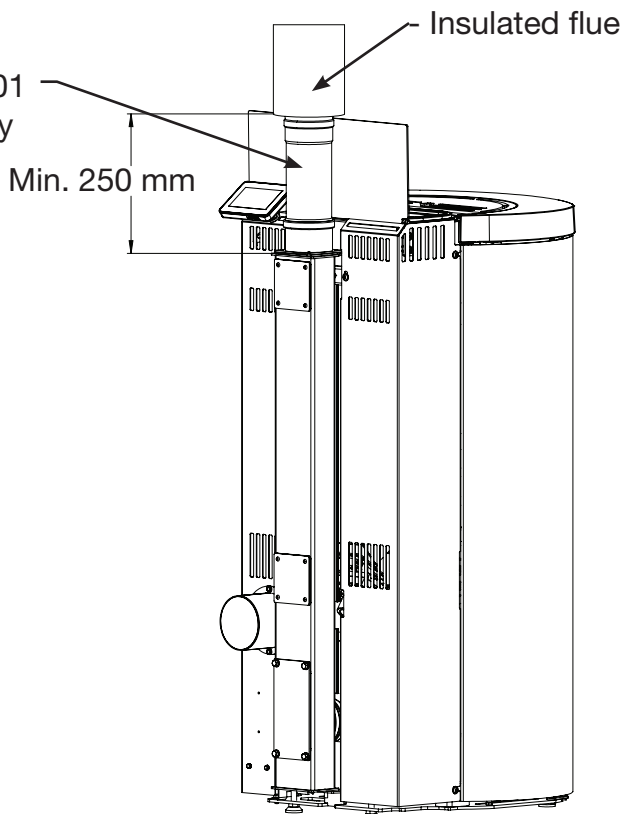

Approved with up to 380 mm Ø 80 mm uninsulated flue as a starting section.

Disassembling soapstone before installation

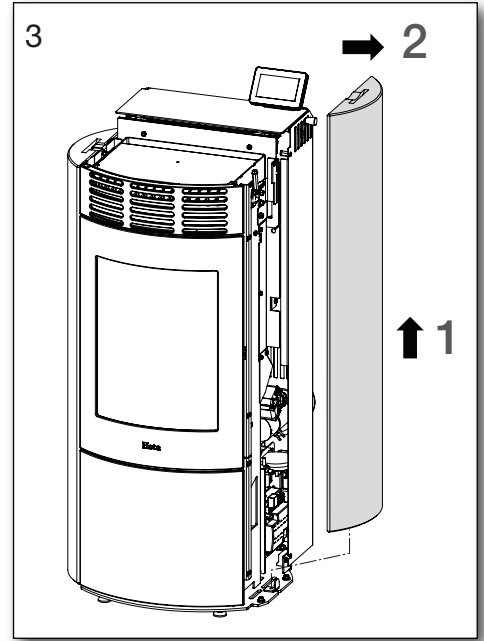
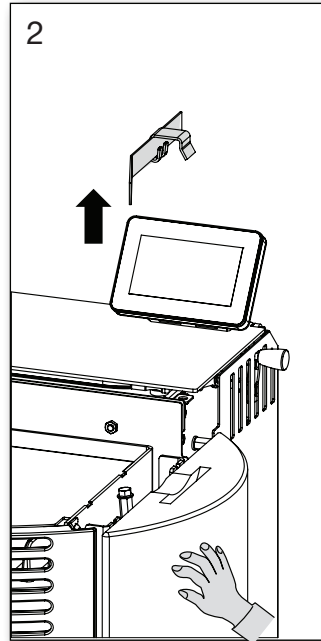
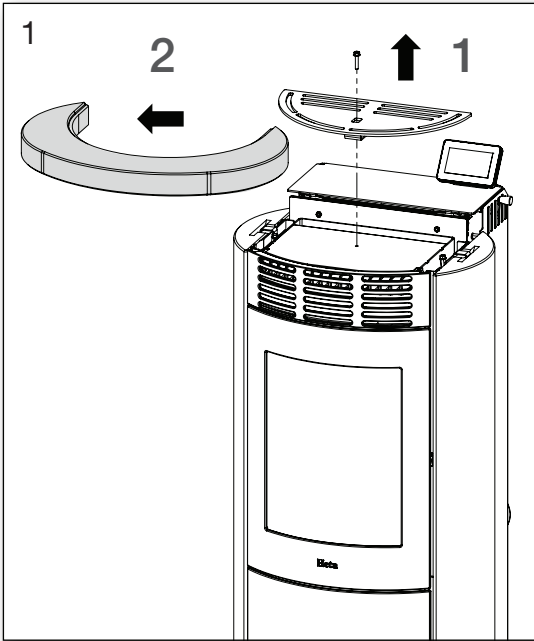

Accessory Installation of WiFi basic (Climate)

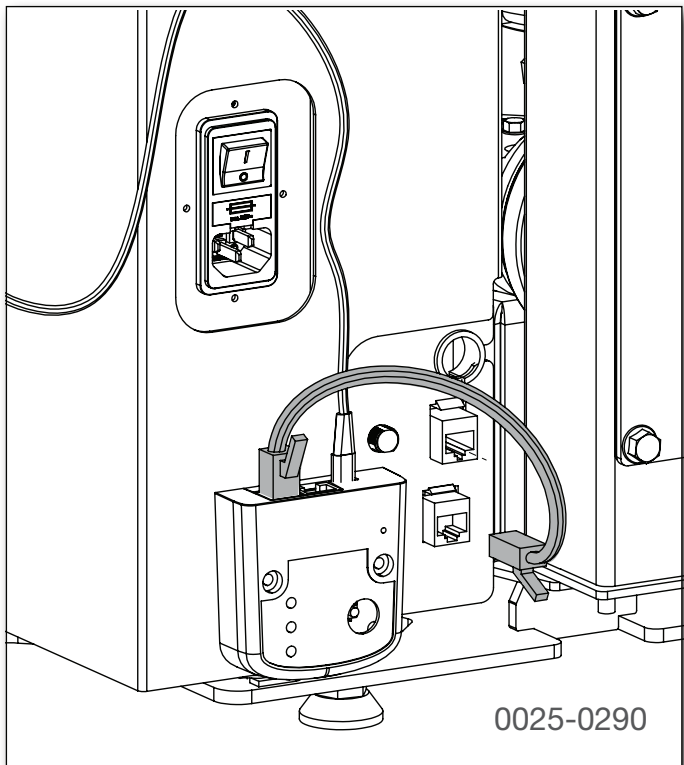

Accessory Installation of WiFi Bluetooth Premium (Pinkey)

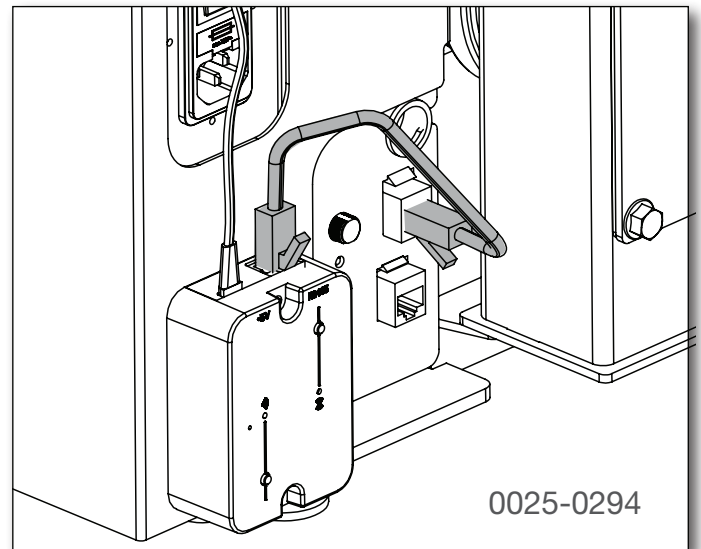

Installation of external fresh air kit Accessory

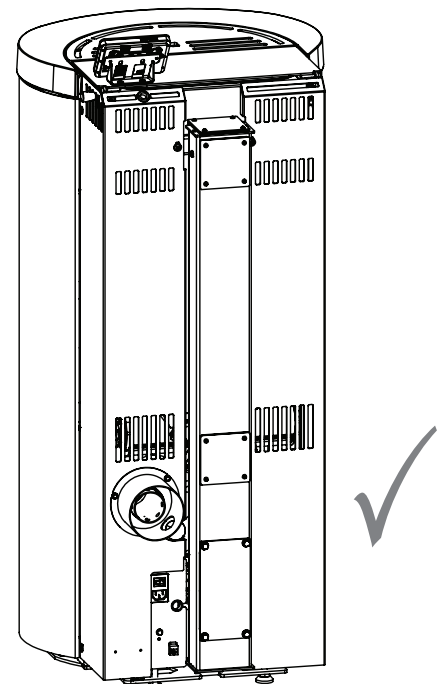
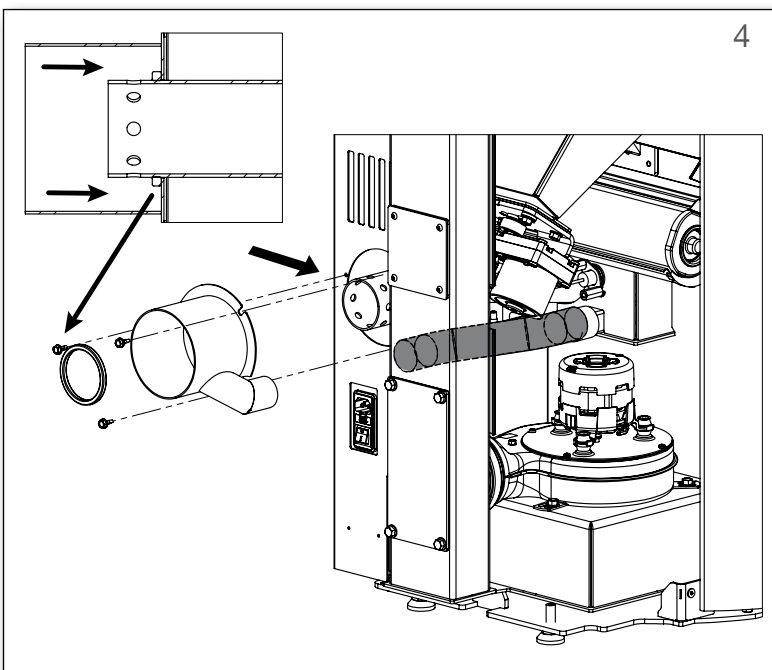
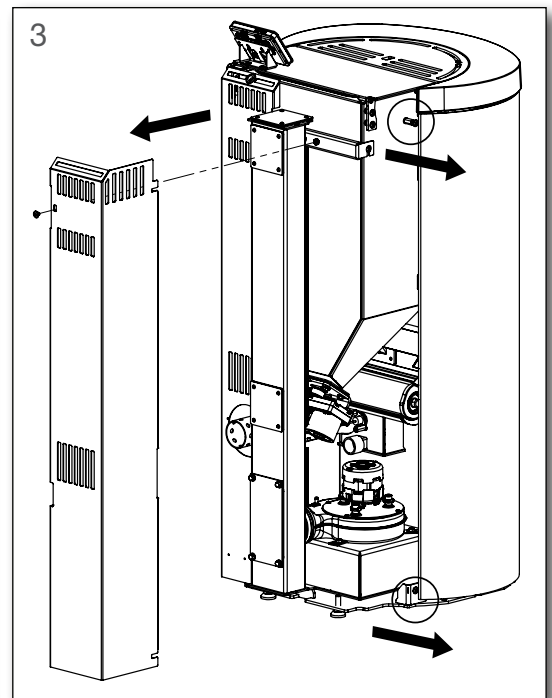
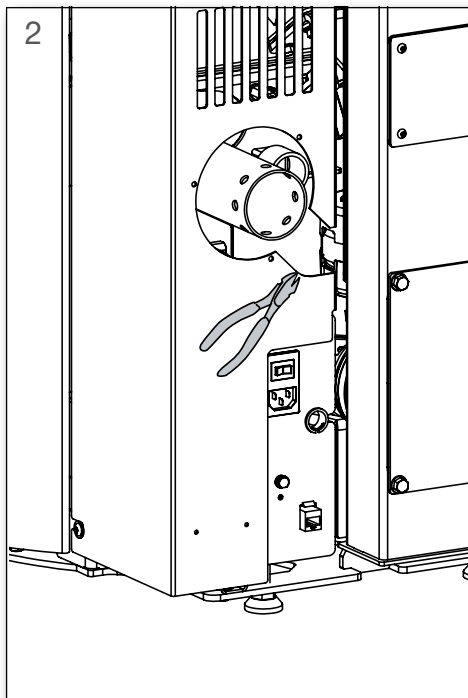
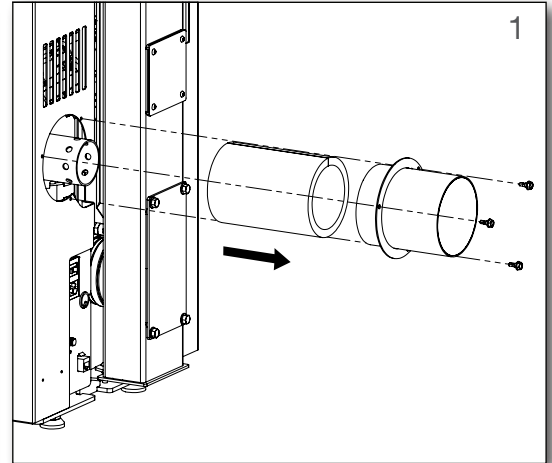
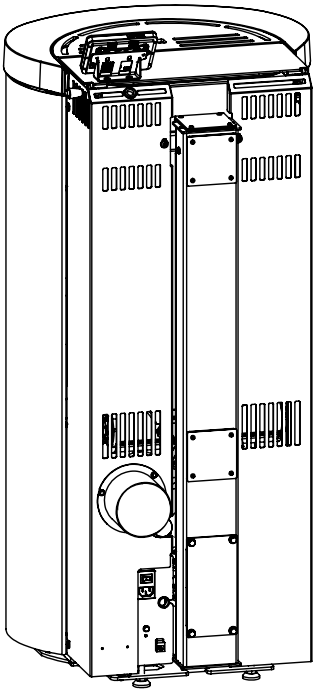

Connection of external fresh air (flex pipe / fixed pipe)

When using external fresh air, the piping must be removed the room (Flex pipe / fixed pipe) must be permanently mounted on the fresh air connection, the joint must be tight.

Flex pipes / fixed pipes must be mounted on the outside the fresh air connection.

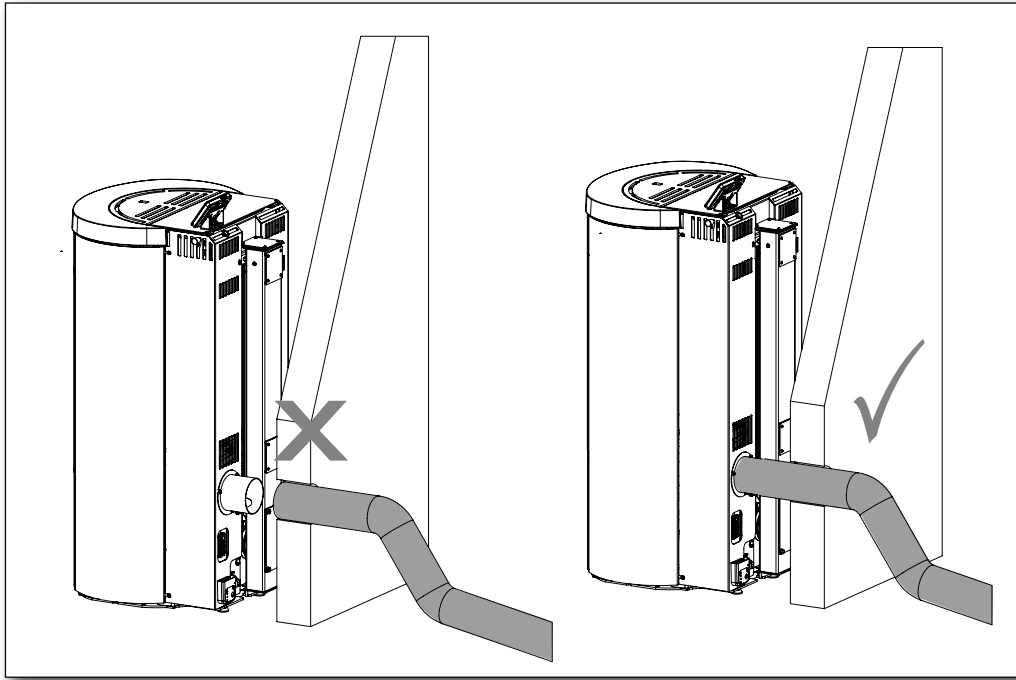

Stovedrawings/measurments

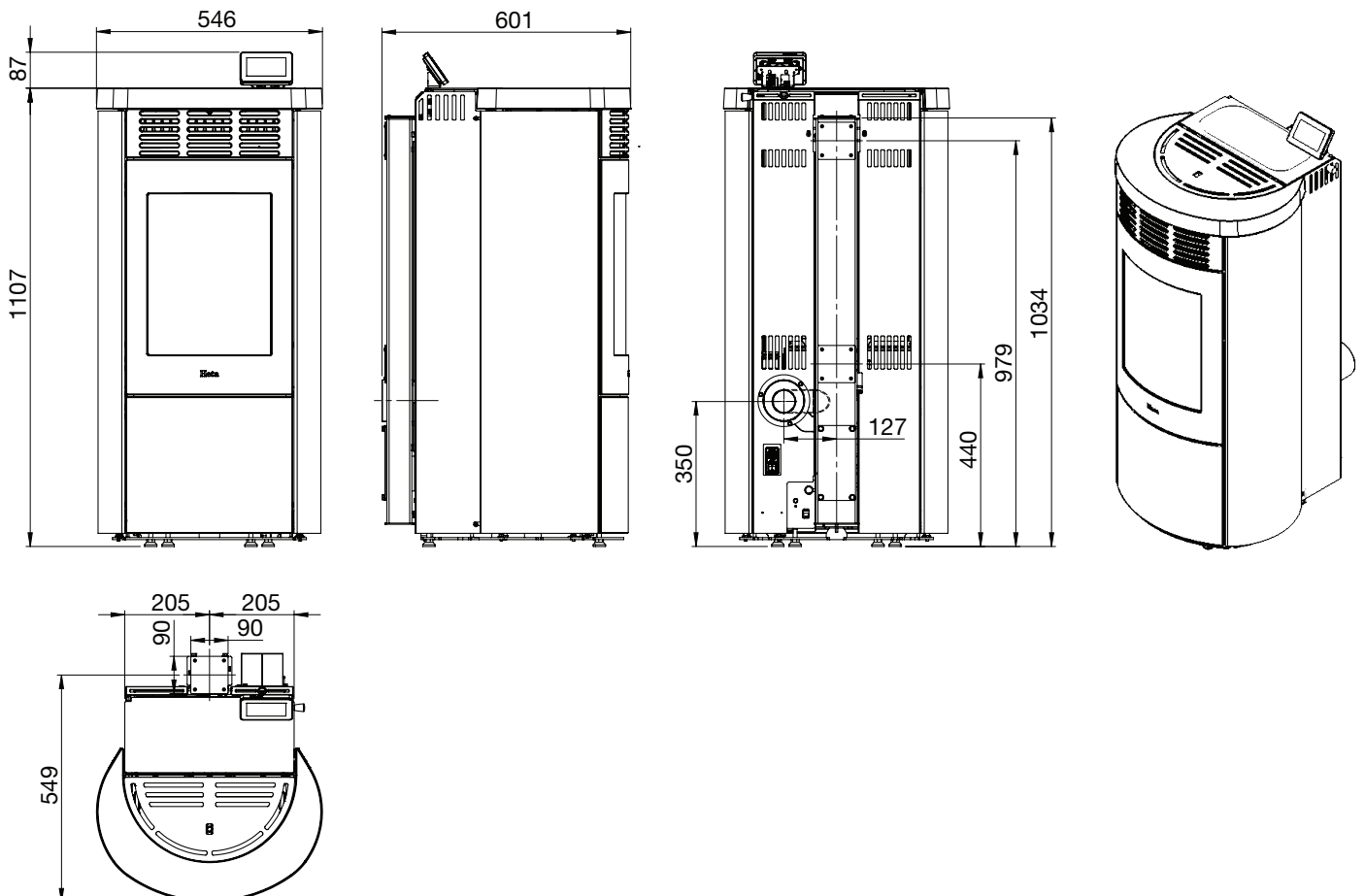



Ecodesign
EU Declaration of Conformity

DoC Scan-Line Green 250 2559-2021

Product fiche



Manufacturer	Heta A/S
Address	Jupitervej 22, DK 7620 Lemvig
E-mail	heta@heta.dk
Website	www.heta.dk
Telephone	+45 9663 0600

Model identifier	Scan-Line Green 250, Scan-Line Green 250 Stone
-------------------------	--

The object of the declaration described above is in conformity with:
The relevant Union harmonization legislation:
DIR 2009/125/EF
REG (EU) 2015/1185
REG (EU) 2015/1186
REG (EU) 2017/1369
REG (EU) 305/2011
The relevant harmonized standards
EN 16510-1-2022
EN 16510-2-6-2022

Characteristics when operating with the preferred fuel only		
Heat output		
Item	Symbol	Value/Unit
Nominal heat output	P_{nom}	8,8 kW
Minimum heat output	P_{min}	3,7 kW
Useful efficiency (NCV as received)		
Useful efficiency at nominal heat output	$\eta_{th, nom}$	95%
Useful efficiency at minimum heat output	$\eta_{th, min}$	97%
Auxiliary electricity consumption		
At nominal heat output	$e_{l, max}$	0,060 kW
At minimum heat output	$e_{l, min}$	0,043 kW
In standby mode	$e_{l, SB}$	0,003 kW

Type of heat output/room temperature control	
single stage heat output, no room temperature control	No
two or more manual stages, no room temperature control	No
with electronic room temperature control	No
with electronic room temperature control	No
with electronic room temperature control plus day timer	No
with electronic room temperature control plus week timer	Yes

Other control options	
room temperature control, with presence detection	No
room temperature control, with open window detection	No
with distance control option	Yes

Notified body relevant to the assessment and verification of constancy of performance
Danish Technological Institute, DK-8000 Aarhus No. 1235. Report no. 300-ELAB-2559-EN_rev. 1

Fuel	Preferred fuel	Other suitable fuel
Wood logs with moisture content $\leq 25\%$	No	No
Compressed wood with moisture content $< 12\%$	Yes	No
Other woody biomass	No	No
Non-woody biomass	No	No
Anthracite and dry steam coal	No	No
Hard coke	No	No
Low temperature coke	No	No
Bituminous coal	No	No
Lignite briquettes	No	No
Peat briquettes	No	No
Blended fossil fuel briquettes	No	No
Blended biomass and fossil fuel briquettes	No	No
Other blend of biomass and solid fuel	No	No

Emissions at heat output	$\eta_s\%$	mg/Nm ³ (13 % O ₂)			
		PM	OGC	CO	NO _x
	≥ 79	≤ 20	≤ 60	≤ 300	≤ 200
Nominal heat output	93	18	< 4	31	168
Minimum heat output		18	8	218	170

Technical documentation	Nominal heat output	Minimum heat output
Indirect heating functionality:	N0	N0
Direct heat output:	8,8 kW	3,7 kW
Energy Efficiency Index (EEI):	EEI 134	
Fluegas temperature at nominal heat output	T 87°C	T 47°C
Energy efficiency class		

Safety	
Reaction to fire	A1
Test of fire safety in connection with the burning of wood	Approved
Distance to combustible materials Rear. Without insulation / with insulation Sides distance to combustible materials Furniture distance	Minimum distances in mm 80 150 650

Signed on behalf the manufacturer of 07.11.2025

HETA
Jupitervej 22, DK-7620 Lemvig
TLF: +45 96 63 06 00
Martin Bach

The chimney sweep's signature Date _____

Signature _____

