

OPERATING AND INSTALLATION INSTRUCTIONS

SCAN-LINE TURIN CLASSIC SCAN-LINE TURIN MODERN



www.hetaheating.com

ECODESIGN READY



EN

DANISH DESIGN . DANISH QUALITY . DANISH PRODUCTION

Congratulations on your new wood stove, we are confident that you will be more than satisfied with your new Heta stove. Especially if you follow the following advice and instructions.

Scan-Line Turin have been approved according to the EN 16510, NS 3058, NS 3059. These approvals, means that the wood stove meets a variety of specifications and requirements, ensuring it is made of quality materials, minimum environmental impact and that it has an optimum fuel economy.

The above declared values apply to all variants of the Scan-Line Turin.

Operating Instructions Contents

Before installation.....	3-4
1. Operating instructions.....	5
1.1 Before using	5
1.2 First firing	5
1.3 Regulating the airflow.....	5
1.4 Lighting the stove.....	5
1.5 Refueling	5
1.6 Emptying the ash	6
1.7 Reduced burning.....	6
1.8 Risk of explosion.....	6
1.9 Draft conditions in the chimney	7
1.10 Fuel.....	7
1.11 Operating problems	8
1.12 Chimney fire	8
1.13 Maintenance.....	8
1.14 Cleaning the glass.....	8
1.15 Cleaning the oven	9
1.16 Cleaning after sweeping or before replacing vermiculite stones	9
1.17 Diagram for maintenance.....	10
1.18 Stove data table EN 16510	10
1.19 Troubleshooting	11
1.20 Parts.....	12
1.21 Garantee.....	13
2. Installation Instructions	14

Heta A/S

Jupitervej 22,
DK-7620 Lemvig

Phone: +45 9663 0600
E-mail: heta@heta.dk

Copyright © 2014
Heta is a registered
trademark of Heta A/S

Printed in Denmark
Subject to printing errors
and changes.

06.02.2026
0037-1214 Version 2.4

BEFORE INSTALLATION

Heta wood stoves are quality products, therefore, your first impression is very important! We have a good logistics network, which transports Heta products with great care for our dealers. Nevertheless, when in transport or handling, damage of the often-heavy stoves can occur. It is important that upon receipt check your Heta product completely and report any damage or defects to your dealer.

The packaging must be disposed of as follows:

Wood is untreated and able to burn in the stove.

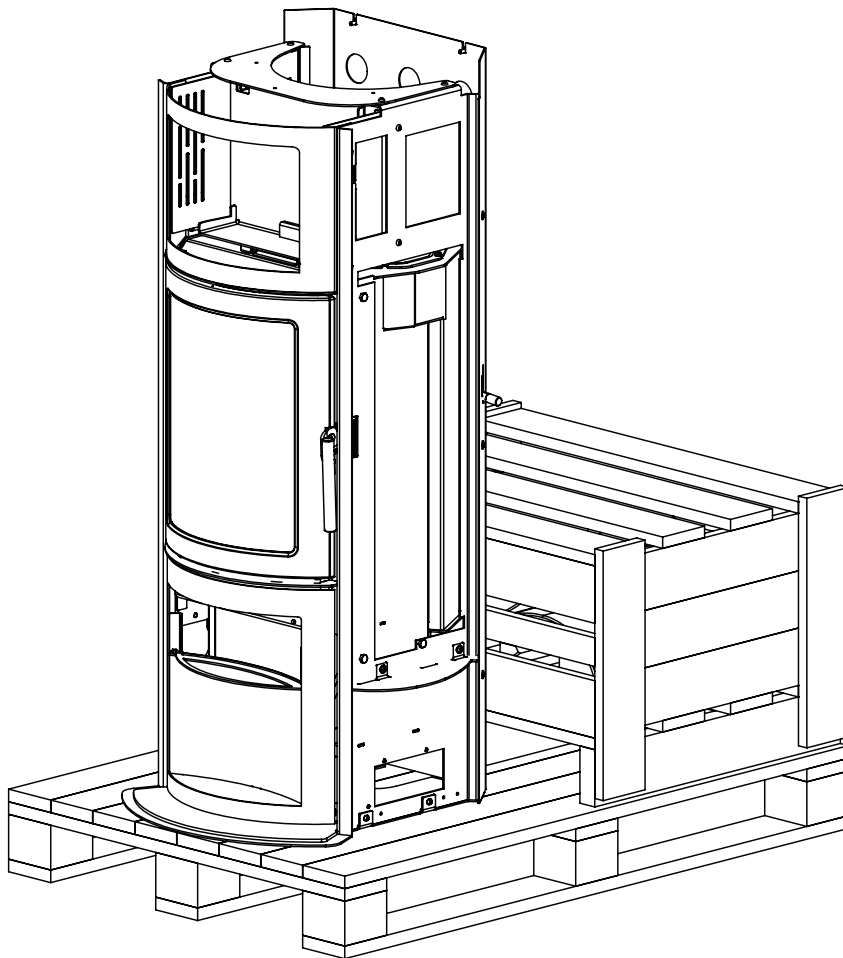

Plastic and cardboard you can drop off at your local recycling center.

Unpacking the stove



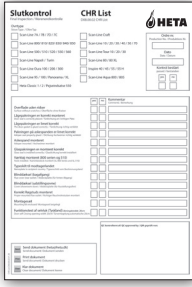

With your new wood stove you should find the following:

<p>Operating / Instruction manual</p>	
<p>Heta glove 0023-9002</p>	

<p>Q.C. check</p>	
<p>Data plate</p>	

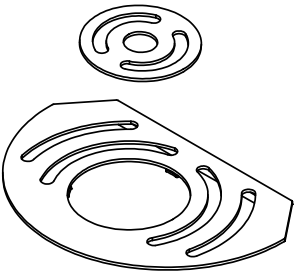
Required tools are not supplied.

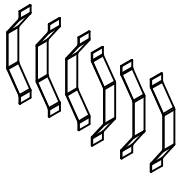
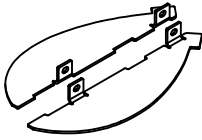
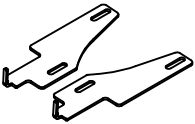
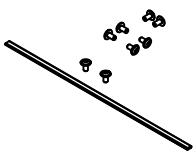
<p>Comes with the oven</p>	
<p>1 piece metal grate 1526-0026</p> 	<p>2 pieces spacer 3 mm 1013-0716 2 pieces spacer 2 mm 1013-0715 2 pieces spacer 1 mm 1013-0304</p> 
<p>6 pieces steel springs 1021-5012</p> 	<p>Side base plates 1 piece 1013-0370 1 piece 1013-0369</p> 
<p>Fixing bracket 1 piece 1013-0380 1 piece 1013-0379</p> 	<p>8 pieces M6x12 0008-0006 Glass tape 2 x 8 0023-3013 L = 0,24 m</p> 

Accessory
Roasting pan
for oven

Nr. 0050-0304

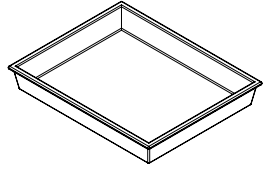

Accessory
Tool and tool holder for mounting on
the back of the stove.

No. 6000-022625



1. OPERATING INSTRUCTIONS

1.1 Before using

Before the wood stove is used make sure required installation conditions, are met. See page 14.

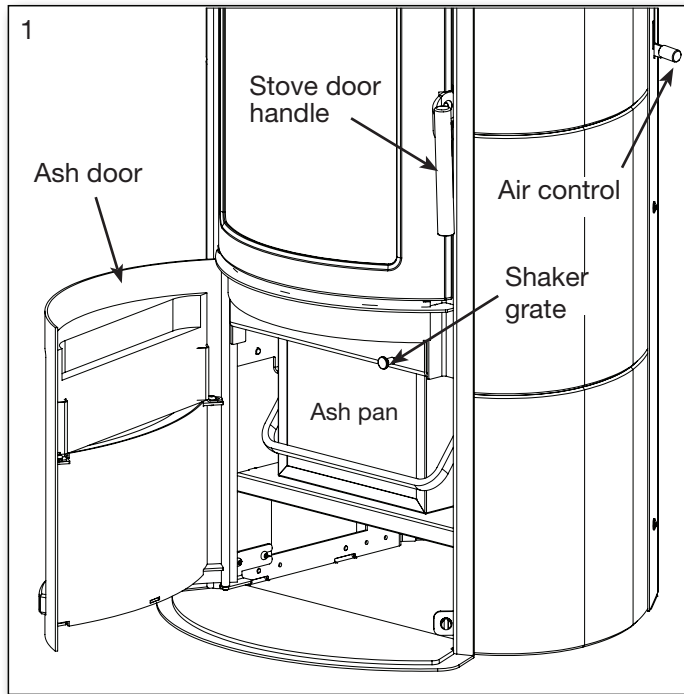

1.2 First firing

The stove paint is fully cured from the factory, but a minor unpleasant odour could still arise.

1.3 Regulating the air flow

To open the flow of combustion air, use the operating handle at the back of the side panel. The combustion airflow is completely open in top position, fig. 2. Shut off the combustion airflow gradually by lowering the handle. The supply is completely shut off when the handle is at its bottom position, fig. 3.

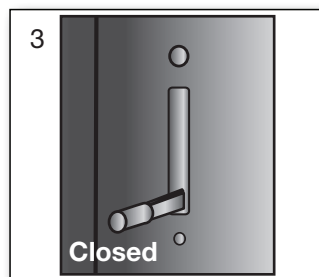
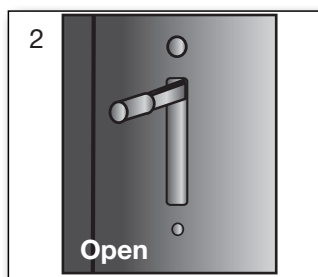

1.4 Lighting the stove

Place two pieces of wood on the bottom. Stack kindling on top in layers with air between. Setting fire starter (bag, brick, paraffin) on the top,

4



now you are ready to light the fuel. The flames must work from the top down. Fig. 4.



The use of lighter fluid, oils or any liquid fuels is strictly forbidden from use in a wood stove.

Fully open the combustion air and leave the door ajar (about 1 cm open).

Once the fire is established and the chimney is hot (after about 3-5 minutes) closed door and regulate the air into operating position. We recommend, all of the first fuel is burned with the combustion air fully open in the operating position. This ensures the stove and chimney are thoroughly heated.



Startup/Lighting

Scan the code and select a language.

1.5 Refueling

Refueling of your stove should be done while there is still a good layer of embers. Distribute the embers with the majority of them to the front. Place pieces of wood equivalent to about 2.24 kg on top of the embers perpendicular to the door. Now open the combustion air completely. If the stove and/or chimney cools down too much, it may be necessary to have the door ajar. Fig. 5

The wood will then ignite within a very short time (Typically 1 to 3 minutes). Once the fuel is ignited. When the fire is well established, you can now regulate the operating air to the desired combustion level.

The nominal output of 6 kW is equivalent to a firing interval of approx. 45 minutes at 38% open combustion air and 1.24 kg of wood.



Ensure when refueling that the wood is not too close, it will cause poorer combustion, less heat out-put and lower efficiency.

The fuel load, must be maintained below the top series of air holes and within the outer vent in each side. Fig. 6.

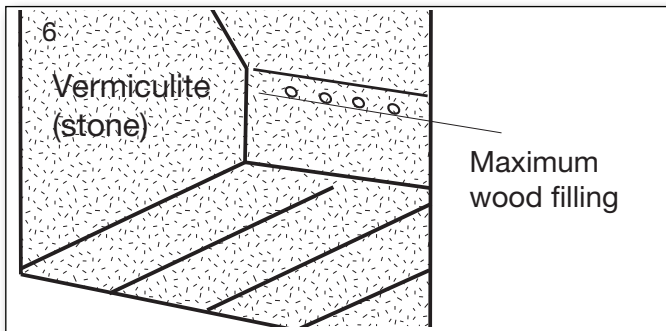

When refueling be careful to place the fuel into the combustion chamber gently, (use the provided glove). By not doing so you risk cracking or breaking the vermiculite.

If there is reduced draft in the chimney, we recommend opening a window at stoking. This will give better ventilation to the room and more oxygen for combustion.



When refueling a maximum load of wood may not exceed 1,6 kg. If this amount is exceeded, the guarantee will be void.

1.6 Emptying the ash

By using the shaker grate, it rotates back and forth so the ash falls through the holes and into the ashtray. It is advantageous to leave a layer of ash in the bottom of the combustion chamber on top of the grate as insulation.



Be careful when emptying the ashes out. There can be hot embers left for a long time.

Never empty ash into a combustible container.



The ashtray must be secure and must not be able to move after being set in place. FIG. 1-4.

Do not fire in the oven if the ashtray is not in place.

The warranty is void if it is not complied with.

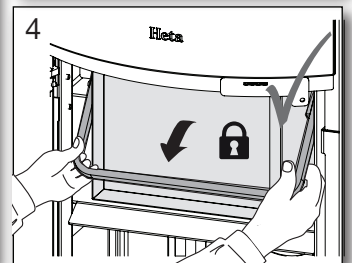
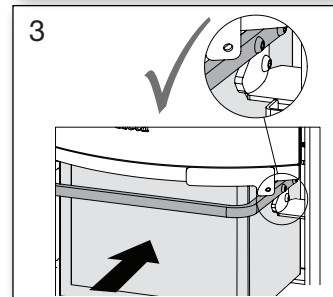
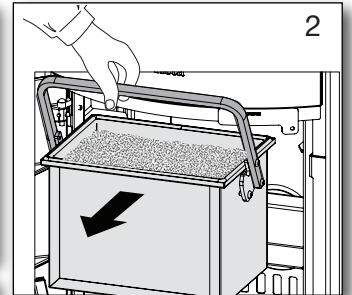
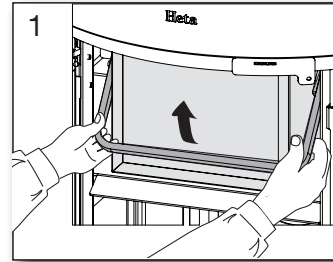

1.7 Reduced burning

The stove is, designed for intermittent use.

It is important to maintain the layer of hot embers. Lower heat out-put occurs when no flames are coming from the wood and it is becoming hot embers.

If you are looking for less heat out-put, achieve this by fueling with smaller volumes of wood and a lower operating air. You may not completely close the operating air during firing.

Be aware that the stove will naturally soot if the operating air is too low. This is not good for the environment. There is also a risk for the glass, the chimney and other parts will become sooted.

By a combination of the above and possibly burning damp wood. Can lead to high levels of soot that it becomes sticky. Causing the sealing of the door to tear off when opening the door the next day.

1.8 Explosion!!!



It is very important never to leave The stove after start up or refueling, before the fire is established. (Typically 1 to 3 minutes)

Explosion can occur if filled with too much fuel in the stove, the production of large volumes of gas, which can explode if the air supply becomes too low.

Warning!



One must always use caution around the stove seen, as it gets very warm during use. (In excess of 90° C).

Children should avoid contact with the stove.

Setting up a fence if you have small children may be necessary.

Do not place flammable objects like drying racks, furniture, curtains too close to the stove.

1.9 Draft conditions and the chimney

Poor draft will not allow the stove to burn, as it should. The glass can soot, requires cleaning of the chimney more often, smoke can escape out when the door is open and it gives poor fuel efficiency. Leading to unnecessary polluting of the environment.

Good draft will allow the stove to achieve optimal combustion and the highest possible efficiency. Heta wood stoves are constructed so that it itself provides an optimal blend of combustion air. This provides a high efficiency/heat, clean glass and low environmental impact.

Minimum chimney draft: 11 pascal.

It is the draft that the stove has been tested and approved on. The minimum draft is necessary to provide clean burning, beautiful flame picture, as well as achieving the rated efficiency.

There is a risk of smoke escaping into the room if the door is opened during vigorous firing, or if there is a lack of air supply to the room, for ex. if an extraction fan is in use.

Nominal fluegas temperature: 243° C, relative to 20°C. Flue gas flow is: 5.2 g/sec. Corresponding to 18.7 m³ / hr of combustion air by burning 1.24 kg of wood.

The chimney height and diameter, as well as the temperature difference between the flue gas and outside temperature generates the chimney draft. Chimney insulation is therefore important as new efficient stoves create lower flue temperatures. Wind and weather conditions also influence draft, in some cases it may be disadvantageous wind direction, combined with the position of the chimney can cause negative draft

(it blows through the chimney), causing smoke escape from the stove.

Before using after a long period of inactivity, check that the chimney is free for any blockages. (soot build-up, bird nests, leaves etc.).

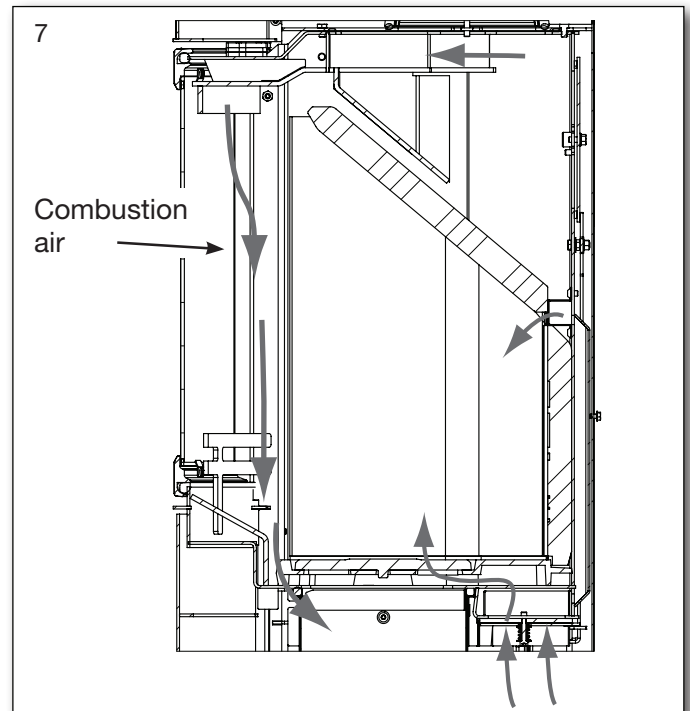

Reduced draft can occur when:

- The temperature difference is too small between smoke gasses and outdoor temperature, for eg. poorly insulated chimney
- Too short of a chimney
- The outside temperature is high, and indoor temperature is low for eg. in summer
- False air in the chimney
- Chimney is blocked
- Air tight house (lack of combustion air supply)
- Poorly placed chimney for the surroundings, for ex. the ridge and trees may cause turbulence

Good draft occurs when:

- The difference in temperature in the chimney (warmer) and outside temperature (colder)
- It is clear weather
- The chimney has the right height min 4 meters above the stove, and clear of the roof ridge

1.10 Fuel

Your new stove is EN approved for firing with wood fuel. You must therefore only burn clean, dry wood in your stove. Never use your stove to burn driftwood, as this may contain a lot of

salt which can damage both the stove and the chimney. Similarly, you must not fire your stove with refuse, painted wood, pressure-impregnated wood or chipboard, as these materials can emit poisonous fumes and smoke.

Correct firing using well seasoned wood provides optimal heat output and maximum efficiency. At the same time, correct firing prevents environmental damage in the form of smoke emissions and reduces the risk of chimney fires.

If the wood is damp and inadequately seasoned, a large proportion of the energy in the fuel will be used to vaporize the water and this will all disappear up the chimney. Thus, it is important to use dry, well seasoned wood, for eg. wood with a moisture content of less than 20 %. Achieve this by storing the wood for 1–2 years before use.

Pieces of firewood with a diameter of more than 10 cm should be split before storing. The pieces of firewood should be of an appropriate length (approx. 22-30 cm) so that they can lie flat on the bed of embers.

Examples of fuel values

for different woods and their typical densities per cubic meter, specified for 100% wood with a moisture content of 18%.

Wood	kg/m ³	Willow	kg/m ³
Beech	710	Wood	560
Oak	700	Alder	540
Ash	700	Scotch pine	520
Elm	690	Larch	520
Maple	660	Lime	510
Birch	620	Spruce	450
Mountain pine	600	Poplar	450

It is advised not to use oil-containing woods like teak tree and mahogany, as this can cause damage to the glass.

Heating value in wood

You have to use about 2.4 kg normal wood to replace one litre of heating oil. All woods have almost the same heating value per kg, which is about 5.27 kW/hour for absolute dry wood. Wood with a moistness of 18% has a efficiency of about 4.18 kW / hour per kg, and one litre heating oil contains about 10 kW / hour.

CO₂ release

At combustion 1000 litres of heating oil forms 3.171

tons CO₂. As wood is a CO₂ neutral heat/energy source, you save the environment about 1.3 kg CO₂ every time you have used 1 kg normal wood.

1.11 Operational problems

The chimney must be swept at least once a year, we recommend the use of a NACS (national association of chimney sweeps) registered chimney sweep.

In the event of smoke or malodorous fumes are being produced, you must first check to see whether the chimney is blocked.

The chimney must, of course, always provide the minimum draft necessary to ensure that it is possible to regulate the fire. Please note, however, that chimney draft is dependent on the weather conditions. In high winds, the draft can become so powerful that it may be necessary to fit a damper in the flue gas pipe to regulate the draft. When cleaning the chimney, soot and other deposits may come to fall on the baffle plate, remove and clean it. In cases where the wood burns too quickly, this may be due to excessive chimney draft. You should also check to make sure that the door seal and ash pan seal is intact and correctly fitting.

If the stove it generating too little heat, this may be because you are firing with wet wood. In this case, much of the heating energy is used to dry the wood, resulting in poor efficiency, potentially damaging the vermiculite and an increased risk of soot deposits in the chimney.

1.12 Chimney fire

In case of a chimney fire, which often results from incorrect operation/maintenance or prolonged use of damp wood, close the door and the air supply completely, to help slow/smother the fire. Call the fire department. The stove and chimney must be inspected before use again.

1.13 Maintenance

The surface of the stove is treated with a heat-resistant paint. The stove should be cleaned with a damp cloth.

Any damage to the surface in the form of chips or scratches can be repaired using touch-up paint, which is available in spray cans.

1.14 Cleaning the glass

Incorrect firing, for example using wet wood, can result in the viewing window becoming covered in soot.

This can be removed easily and effectively using glass cleaner applied using a cloth.

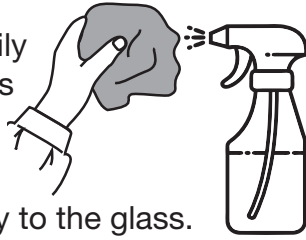

Never apply spray directly to the glass.

1.15 Cleaning the oven

You should attempt not to spill anything directly onto the oven coating. Where necessary, use an aluminium tray to catch any spills.

Clean the oven using hot water and washing-up liquid. Do not use oven cleaner as this may damage the surface.

1.16 Scan-Line Turin. Cleaning after sweeping or before replacing vermiculite stones

Note: it may be necessary to clean/vacuum the holes and air ducts behind the rear stone.

Order of removing Fire bricks.

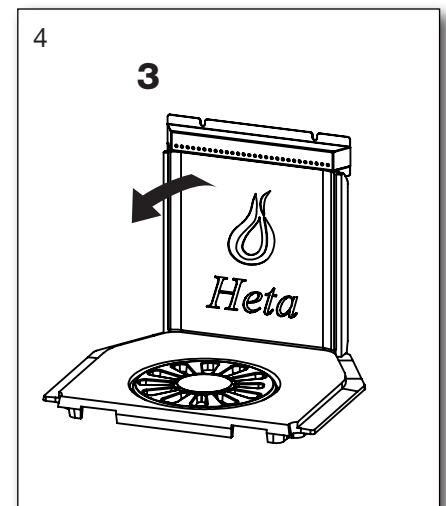
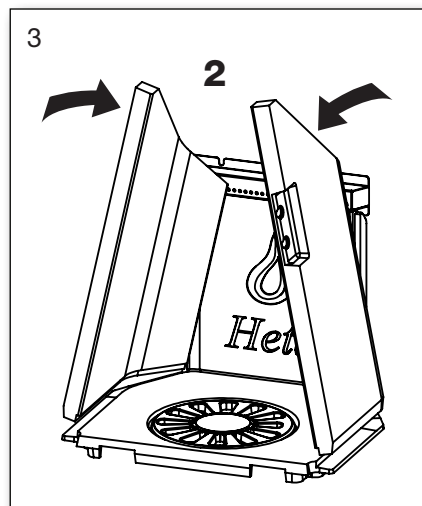
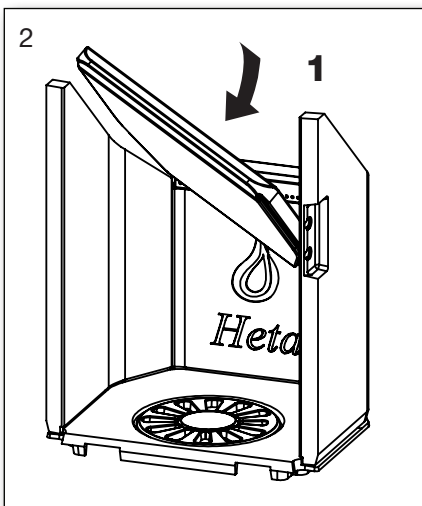
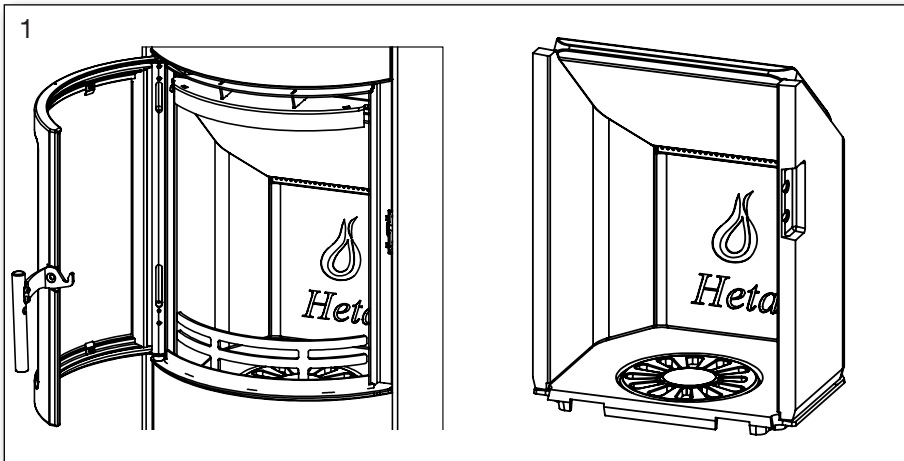

Replace in reverse order. Starting with fig. 4.

1.17 Diagram for the maintenance

Maintenance / Period	Stove Owner					Qualified Technicia	
	Before Autum	Daily	1 week	30 days	60-90 days	1st Year	2st Year
Cleaning the chimney (see. Chimney)	C						
Cleaning the chimney and stove	C				C		
Cleaning the stoves firebox	C	VI			C		
Cleaning combustion air intake	C				C		
Cleaning ash bucket	C		VI	C			
Cleaning of the firebox	C		VI	C			
Checking / switch, gasket for door	C/S	VI					C/S
Checking / changing, gasket for glass	C/S	VI					C/S
Checking / switch, gasket for ashpan	C/S	VI					C/S
Checking / changing gasket for flue pipe	C/S	VI					C/S
Checking / changing vermiculite	C/S	VI					C/S
Lubricate hinges	L	VI			L		
Lubricate lock	L	VI			L		
Lubricate Ash pan	L				L		

C = Cleaning

C/S = Checking /Switch

L = Lubricate

VI = Visual Inspection, pos. cleaning/replacing/adjusting

1.18 Stove data table in accordance with en 16510 testing

Tested as a freestanding oven and with uninsulated flue

Stove type Scan-Line	Nominal fluegas temperature, at 20°C room temperature	Flue mm	Fuel volume kg	Draft min. mbar	Nominal output tested kW	Actual efficiency %	Distance to flammable materials			Stove weight kg
							at the sides mm	rear the stove mm	to furnitures mm	
Turin	243 C°	ø150	1.24	0.11	6,0	82	350	150	1000	*

* Turin Soapstone 274 kg * Turin Ceramic 171 kg

* Turin B Soapstone 277 kg * Turin B Ceramic 180 kg

The nominal output is the output to which the stove has been tested.

Testing is conducted with the combustion air around 38% open.

1.19 Troubleshooting table - applies to all stove types

Fault	Cause	Troubleshooting	Solution
Lighting problems. When the stove is cold, smoke seeps into the room. Once the combustion chamber has heated up, the stove burns well.	Inadequate chimney draft. The chimney only has sufficient draft when it is hot.	You can test using a lighter whether flame is drawn into the combustion chamber.	Improve the chimney.
The stove burns poorly after the warm-up phase, and the glass slowly soots up.	Soot in the flue pipe.	Check the flue pipe regularly, as the problem arises slowly.	Clean regularly, and limit the use of horizontal flue pipes. Do not use firewood which generates large quantities of ash.
If the stove burns poorly after start-up, and the glass slowly soots up.	Inadequate chimney draft.	The fault usually already occurs during lighting. Measure the chimney draft.	Improve the chimney draft.
	Insufficient air supply.	Check the air supply.	Read the operating instructions and instruct all users.
	Damp wood.	Use clean, dry wood with a maximum moisture content of 20%.	Firewood should ideally be dried for at least one year after splitting.
	Firewood pieces too large.	Optimal size – see the section for firewood, max. diameter 10 cm.	Use smaller pieces of firewood.
	Insufficient air supply to the room. Range hoods, airtight windows, etc.	Ensure there is sufficient fresh air supply, open a window, check the outdoor air supply.	Depending on the cause, windows must be opened or the outdoor air connection cleaned.
	Insufficient air supply to the room. Range hoods, airtight windows, etc	Ensure there is sufficient fresh air supply, open a window, check the outdoor air supply.	Depending on the cause, windows must be opened or the outdoor air connection cleaned.
The vermiculite in the combustion chamber is becoming very worn.	Wood and flue gases wear down the vermiculite.	Investigate whether the wear is normal.	Normal wear and minor cracks are of no significance. It should be replaced when the steel of the combustion chamber is visible.
Too rapid combustion.	Too much chimney draft.	To test, you can open the cleaning hatch, but remember to close it again.	Measure the chimney draft and install a damper in the flue pipe if necessary.
	The door or ash pan/drawer seal is defective.	While cold, close a piece of paper in the door – the seal should hold the paper gently in place so it does not fall out by itself. Normal wear.	Replace the seal.
The vermiculite in the combustion chamber is cracked.	Shocks or impacts while adding firewood.	Normal wear	Cracks only have cosmetic significance. Replace when the steel of the combustion chamber is visible.
Steel surfaces in the combustion chamber have oxidised.	The temperature in the combustion chamber is too high.	Unsuitable fuel is being used (such as coal). Check the quantity of firewood being used, read the operating instructions.	If there are clear cracks or weaknesses in the stove body, it must be replaced.
The stove whistles	Too much chimney draft	To test, you can open the cleaning hatch, but remember to close it again.	Install a damper.
The stove 'clunks'	Usually due to tension in the metal plates.	Generally only occurs while heating up and cooling down.	Adjust the metal plates.
The stove ticks	Normal expansion and contraction due to temperature changes.	A normal sound.	Ensure that the temperature in the combustion chamber is as constant as possible.
The stove creaks.	The temperature in the combustion chamber is too high.	Use less firewood. Also check the seal in the ash pan/drawer.	See the operating instructions.
The stove smells. The surface is steaming.	The paint on the stove surface is not yet fully hardened.	See the operating instructions regarding the first firing.	Ensure there is sufficient ventilation.
Condensation in the combustion chamber.	Moisture in the vermiculite.	Check the condition of the vermiculite.	Evaporates by itself after the stove has been lit a few times.
	Damp wood.	Measure the moisture content.	Use dry firewood.
Condensation from the flue pipe.	The pipe is too long or the chimney is too cold.	Check the flue pipe's length and heat loss.	Improve the flue pipe, insulate the chimney.
	Damp wood	Measure the moisture content.	Use dry firewood.
Moving parts creak.	Needs lubrication.	What part.	Lubricate with graphite spray.

1.20 Parts - Scan-Line Turin - Inside fire chamber

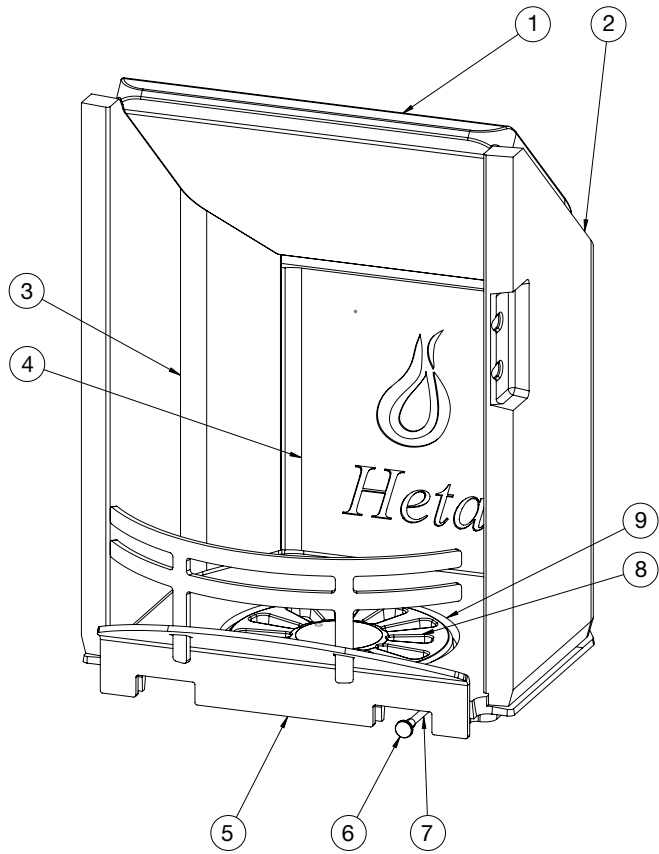

Pos. No.	Name	Qty
1	0023-0075 Upper baffle	1
2	0023-0076 Right side stone	1
3	0023-0077 Left side stone	1
4	0023-0078 Back stone	1
5	1500-022221 Log retainer	1
6	0015-2013 Knob	1
7	1021-4062 Shake pin	1
8	0030-0201 Grate	1
9	0030-0013 Casted bottom	1

Parts - Stove door

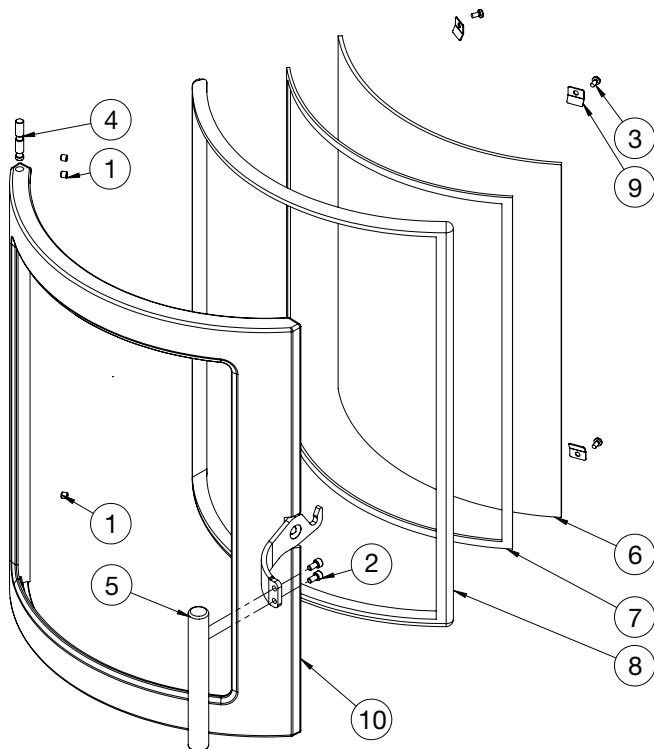

Pos.	No.	Name	Qty.
1	0008-1007	Screw M6x6	3
2	0008-2005	Screw M5x10	2
3	0008-2301	Screw M4x8	4
4	0016-0016	Hinge pin	1
5	1016-0031	Handle	1
6	0021-0024	Glass	1
7	0023-3013	Glass gasket 3x8 L=1,7 m	1
8	0023-3019	Door gasket ø14 L=1,8 m	1
9	1013-0432	Glass clips	4
10	4005-0027	Stove door	1

1.21 Guarantee

Heta wood stoves, are subjected to a strict quality control during production and before delivery to the dealer. Therefore, the duration of the warranty is **5 years** on this product, covering manufacturer's defects, **1 year** on paint adhesion defects from purchase date from Heta.

In addition, there is a **3-month** goodwill warranty, on gaskets, vermiculite and glass from the date of sale from the shop. Photos of the damaged parts must be sent for review.

Claims concerning stoves older than **3 months**, will be assessed by our quality team on a one-by-one basis. Report all claims to your approved / authorised HETA dealer, who in turn will contact Heta to solve the claim. Any stoves purchased online or via a 3rd party carry a standard 1-year warranty with engineer visits and parts being chargeable. To file a claim please provide date of installation, picture of the silver data sticker, model and a description of the issue and pictures.

The guarantee does not cover:

- Wearing parts / fragile parts such as:
- Vermiculite elements in the combustion chamber.
- Glass
- Seals
- The cast bottom or shaking grate
- Surface or paint deteriorations due to excessive humidity, salinity or other aggressive environment
- Damage caused by improper use
- Transportation costs for warranty repair
- Assembly / disassembly of warranty repair
- Any secondary damages of the stove or it's environments due to negligence of any initial damages whether this damage is covered or not by the manufacturers guarantee.

Warning



Inadequate installation, unauthorized alteration to the stove or the use of non-original parts will void the guarantee.

Lubricate Ash pan

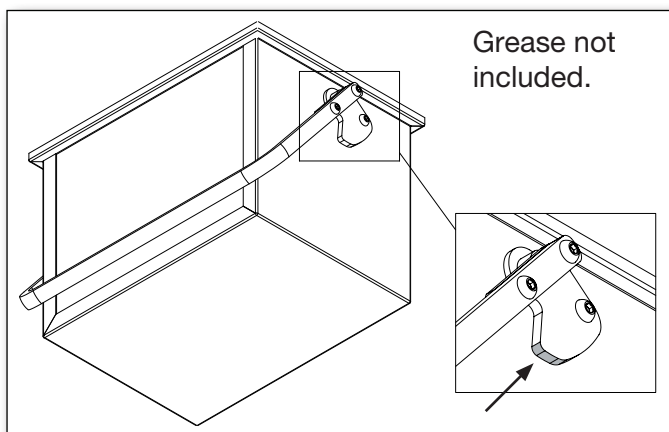

Installation Instructions

Contents

2.	Installation instructions	15
2.1	Distance requirements	15
2.2	Floor	15
2.3	Chimney connection	15
2.4	Combustion air and ventilation	16
2.5	Stovedrawings/measurments	17
2.6	Changing to a back flue outlet	18
2.7	Connecting direct air below or behind	18
2.8	Clearances for installation.....	19
2.9	Installing ceramic panels.....	20
2.10	Installing soapstone elements.....	23
	Appendix A.....	19
	EU Declaration of Conformity	28

Remember

The stove and chimney installation, must comply with local regulations, including those referring to national and European standards.

2. Installation instructions

The stove installation must be in accordance with national, European and possibly local regulations. You must follow local regulations with regard to installation of chimney and connection to the chimney. We recommend that you let a professional Heta dealer install the stove. Alternatively, you can ask the local chimney sweep before installation. Be aware that it is always the owner himself who has responsibility for ensuring that applicable rules are complied with.

A modern stove places heavy demands on the chimney due to the high efficiency. It may be necessary to enhance or even replace an old chimney.

Remember

1. Always ensure free access to any cleaning doors in a chimney.
2. Always ensure ample fresh air to the room.
3. Exhaust/extraction fans in the house can reduce or create negative draft in the chimney. Reduced draft can lead to the stove having adverse combustion properties. It may result in smoke coming out of the stove when the door is open. A negative draft due to an exhaust/extraction fan can cause the chimney to work in reverse, drawing smoke into the house because of the fan.
4. Any air vents must not be covered.

2.1 Distance Provisions

There is a difference between installation next to flammable wall or non-flammable wall.

For non-combustible walls, a minimum of 5 cm is recommended between the oven and the wall for cleaning purposes behind the oven.

The minimum distance to combustibles can be found on the model plate provided with the stove or on page 10 of this manual.

2.2 Floor

You must ensure that the floor can support the weight of the stove and a top-mounted steel chimney.

In front of the fireplace insert, the substrate must consist of non-combustible material, for ex. Steel/glass plate, stone or tile floor. The size of the non-combustible surface must follow the

applicable national and local regulations. Protecting your floor from embers that may fall out of the oven.

Distances see data table page 10.

Pay special attention to the distance from flammable floor, which is also valid even if there are a steel, glass, stone or tile over flammable materials. These stoves can be installed on a 12 mm non combustible hearth.

2.3 The chimney connection

The chimney opening must follow national and local regulations. However, the area of the opening should never be less than 175 cm², which corresponds to a diameter of 150 mm. If a damper is fitted in the flue gas pipe, there must always be at least 20 cm² of free passage, even when the damper is in its “closed” position.

If local regulations permit, two contained stoves can be connected to the same chimney. However, you must abide by local regulations regarding the distance between the two connections.

The stove must never be connected to a chimney that is linked to a gas fire stove.

An efficient stove makes high demand on chimney properties – so always have your local chimney sweep evaluate your chimney.



Connection to a brick chimney

Brick a thimble into the chimney and seat the flue gas pipe in this.

The thimble and flue gas pipe must not penetrate the chimney opening itself, but must be flush with the inside of the chimney duct. Joins between brickwork, the thimble and flue gas pipe must be sealed with fireproof material and / or beading. Heta A/S stresses that it is of utmost importance that this is done correctly with very tight joints. As mentioned earlier, we recommend that setup and installation be left to a professional Heta dealer.

Connection to a steel chimney

The steel chimney must meet T400 at least.

When installing the chimney through the ceiling, national and local regulations must be followed regarding distances to flammable materials.

It is important that the chimney is mounted with a roof support so that the stove's top plate does not support the chimney (the stove is approved to be able to carry 120 kg.)

2.4

Combustion air and Ventilation

The insert stove is approved as a room air dependent insert stove in accordance with EN 16510. All the combustion air in the inset stove comes from the room in which it is fitted. However, by connecting a sealed air inlet to the insert stove's air intake connector, the stove can be supplied with external combustion air. In this respect, the following requirements must be met:

- Only approved materials may be used from the ventilation unit to the air inlet vent.
- The air inlet vent must be fitted correctly and insulated to prevent formation of condensate. The cross section of the vent and grille must be at least 78 cm².
- If the vent leads out into the open air, please note that the grille must be fitted with suitable wind protection. There must be no risk that the grille can get clogged by leaves, etc.

Ventilation

Adequate ventilation must be provided in accordance with building regulations (Doc J Oct 2010) especially when installing in newer build properties when the stove is not going to be installed to an outside air supply.

The Scan-Line Turin has a nominal output of less than 5 kW and does not need additional ventilation in older properties where it will be ventilated by natural leakage.

Houses built after 2008 where the air leakage rate is less than 5 m³ / hour / m² then a ventilator equivalent to 550 mm² per kW output will be required (4.5 kW x 550 mm = 2475 mm²) unless the stove is connected to an outside fresh air supply.

2.5 Stovedrawings/measurments

Scan-Line Turin

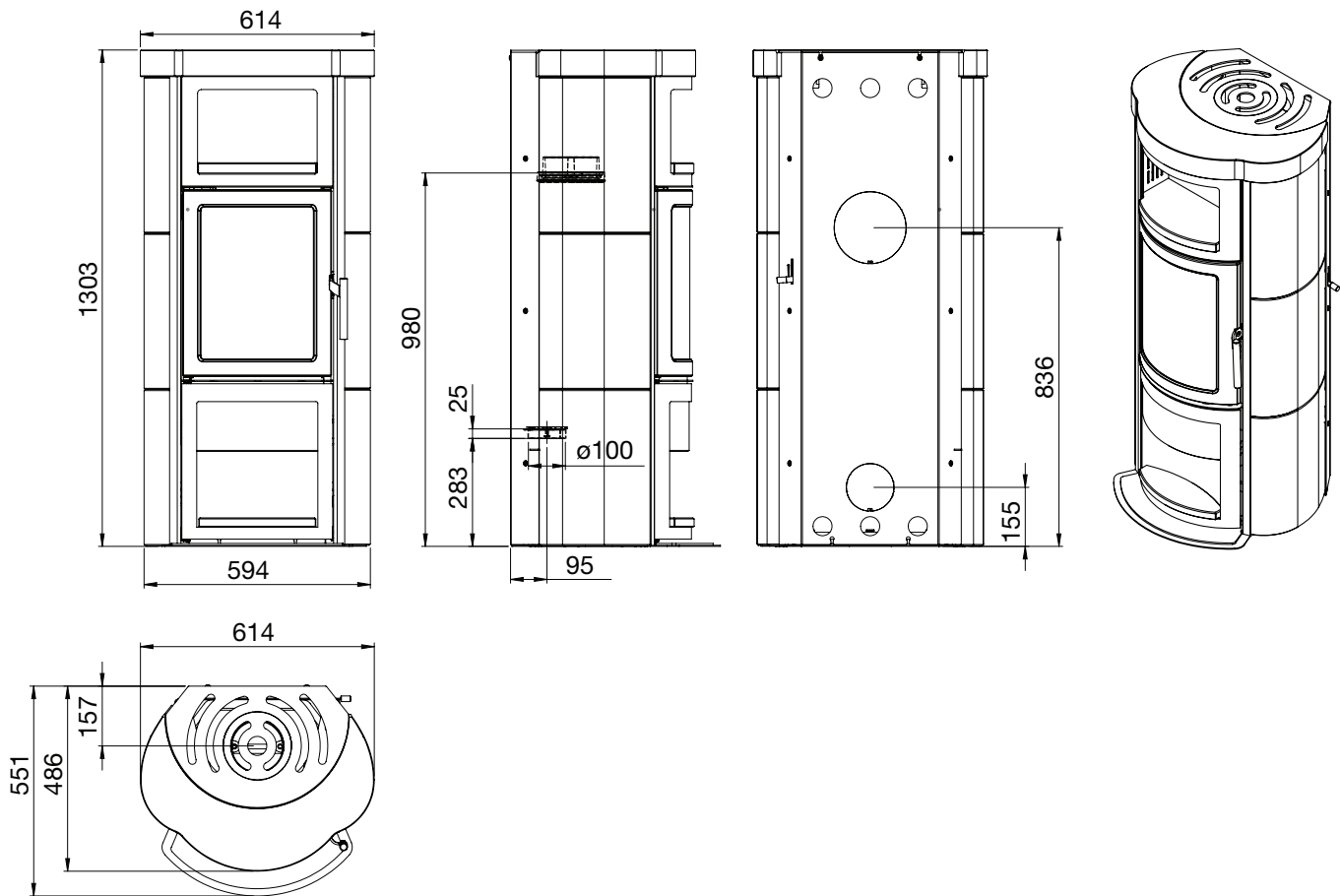

Scan-Line Turin B

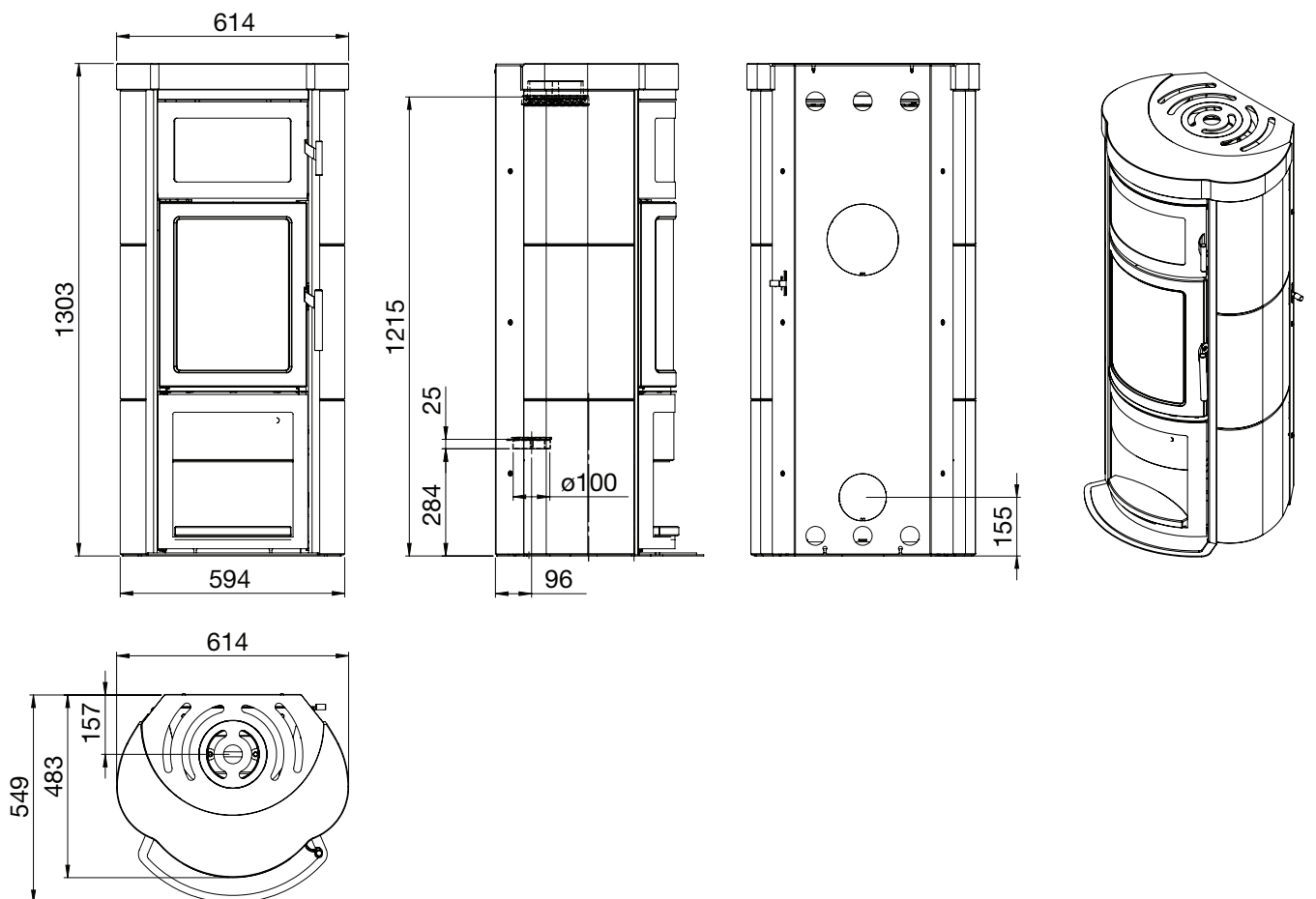

2.6 Changing to a back outlet – does not apply to the oven model

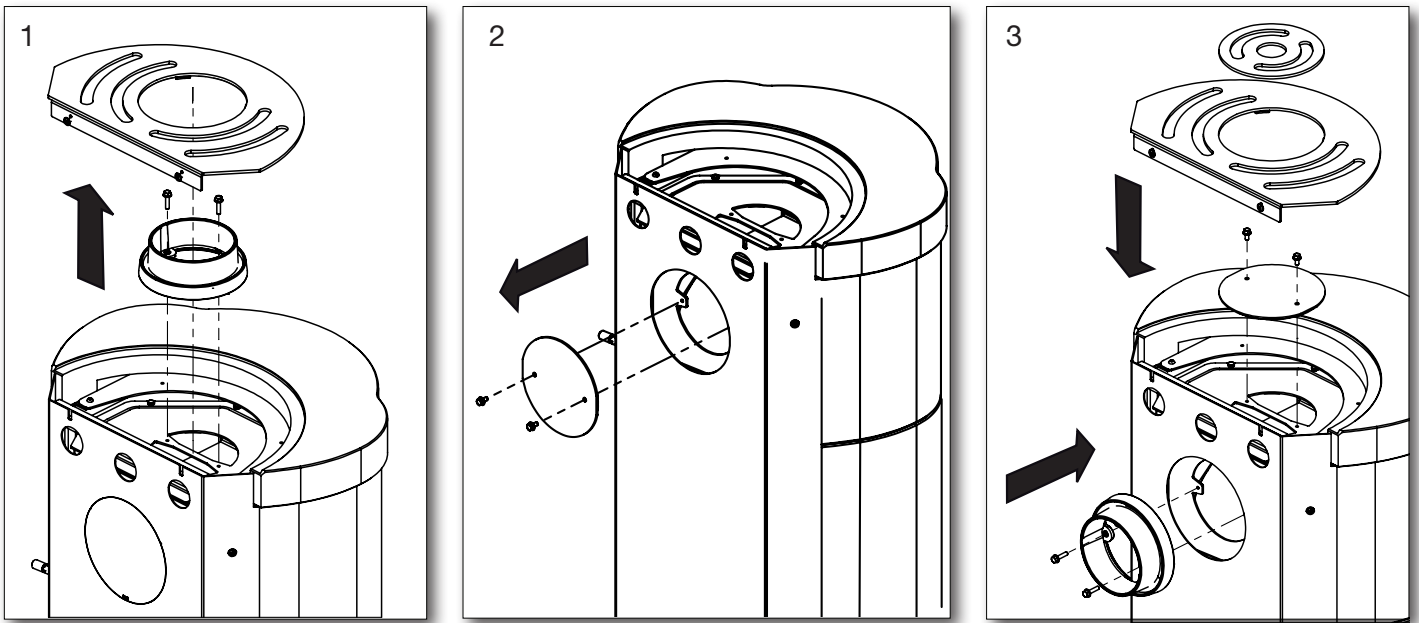

2.7 Connecting direct air below or behind

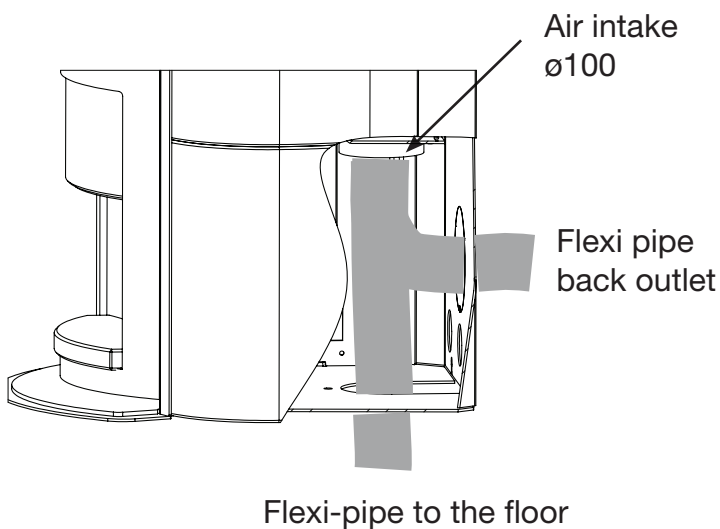

When installing external air supply, connect the air intake to the direct air pipe using flexi-pipe, both from the floor or behind the stove.

Flexi-pipe not included.

Direct air supply

The dimensions of the direct air supply pipe, may not be less than $\text{ø}100$ mm, the draught in the flue depends on this air for optimal combustion.

Heta recommends max. 4 meters of direct air pipe, with max. 3, 90° bends and a min. of $\text{ø}100$ mm.

2.8 Clearances for installation EN 16510

Clearances for installation

Stove	Distance to flammable materials				
	dR rear the stove	dS at the sides	dP at furnitures	dS! Corner distance	dC Over stove Mantel
Scan-Line Turin	150	350	1000	350	750

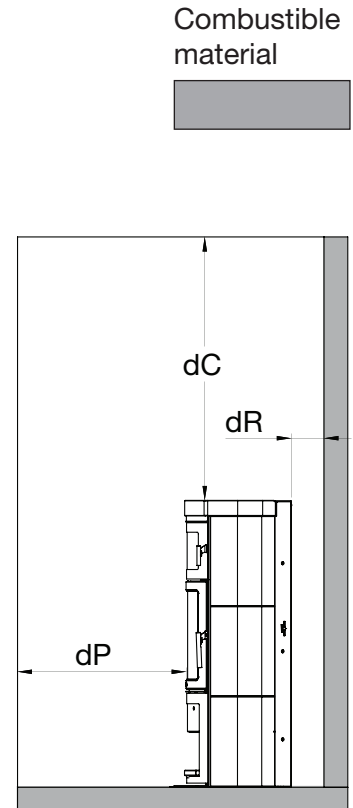
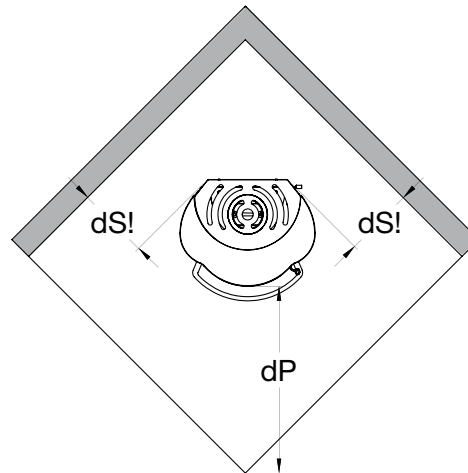
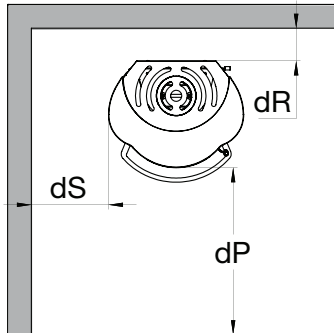

Appendix A

The Clean Air Act 1993 and Smoke Control Areas.

Under the Clean Air Act local authorities may declare the whole or part of the district of the authority to be a smoke control area. It is an offence to emit smoke from a chimney of a building, from a furnace or from any fixed boiler if located in a designated smoke control area. It is also an offence to acquire an "unauthorized fuel" for use within a smoke control area unless it is used in an "exempt" appliance ("exempted" from the controls which generally apply in the smoke control area).

In England appliances are exempted by publication on a list by the Secretary of State in accordance with changes made to sections 20 and 21 of the Clean Air Act 1993 by section 15 of the Deregulation Act 2015. Similarly, in Scotland appliances are exempted by publication on a list by Scottish Ministers under section 50 of the Re-

gulatory Reform (Scotland) Act 2014. In Wales and Northern Ireland these are authorized by regulations made by Welsh Ministers and by the Department of the Environment respectively.

Further information on the requirements of the Clean Air Act can be found here:

<https://www.gov.uk/smoke-control-area-rules>

Your local authority is responsible for implementing the Clean Air Act 1993 including designation and supervision of smoke control areas and you can contact them for details of Clean Air Act requirements

The Scan-Line Turin with and without side windows have all been recommended as suitable for use in smoke control areas when burning dry wood logs.

2.9 Installing ceramic panels

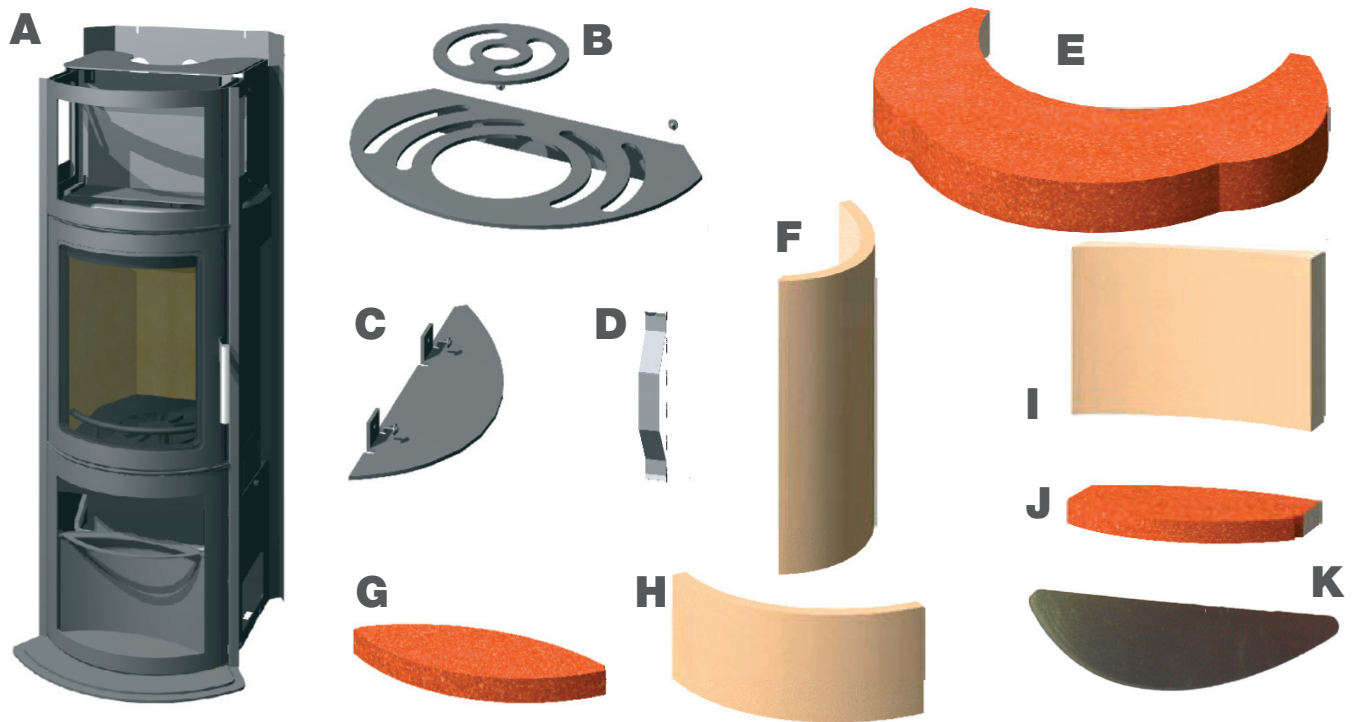

1.0 Overview of the components:

- A) A wood-burning stove
- B) A metal grate
- C) Two side base plates with screws
- D) Six steel springs
- E) A ceramic top panel
- F) Six ceramic sides
- G) A base panel for the ash door
- H) A radius panel for the ash door
- I) A back panel for the shelf
- J) A bottom for the shelf
- K) Six spacers for adjusting the height of the sides.

1.1 Preparation

1.1.1

If the stove is connected using the top flue pipe, metal grate B must be installed before the flue pipe is connected.

1.1.1

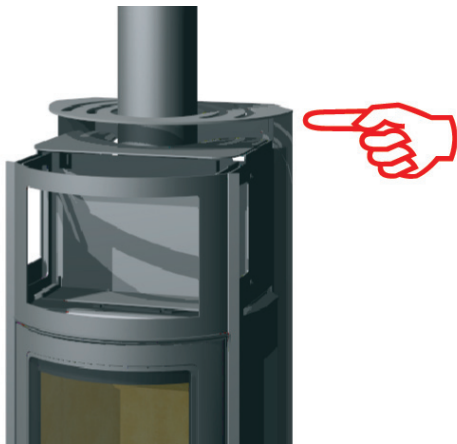

1.1.2

Before the ceramic cladding is affixed, the side base plates (C) must be screwed onto the stove.

1.1.2

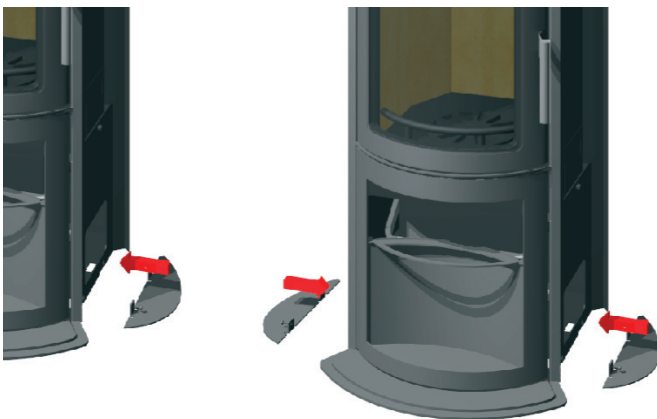

1.2.1

Insert the bottom right panel in behind the back wall and rotate the front towards the stove.

1.2.1

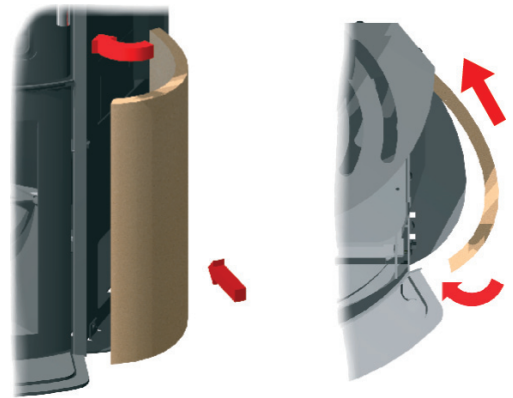

1.2.2

Push the side panel forward behind the edge of the plate. Insert a steel spring (D) between the back wall and the side panel to hold the side panel in place.

1.2.2

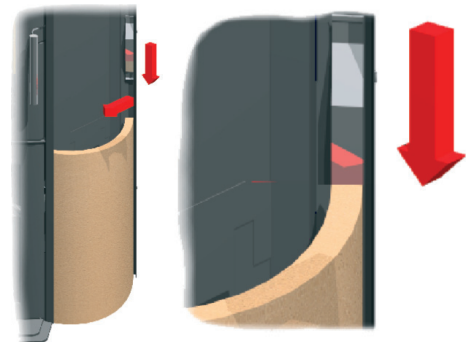

1.2.3

Install the five remaining side panels in the correct order, as described in 1.2.1 and 1.2.2.

1.2.3



1.2 Installing the ceramic panels

Remember that the ceramic panels can break! They must be installed very carefully!

Lie the three panels for each side adjacent to each other, or put in place without springs and measure the height. Adjust for any difference in relation to the stove by placing the spacers provided on top of the side base plates (C).

1.2.4
Place the base panel (G) at an angle inside the ash door and rotate into position.



1.2.7
Place the shelf panel (J) at an angle inside the cooking section and rotate into position



1.2.5
Open the ash door and loosen the hex screws on the holding brackets. Insert the radius panel (H) from above between the holding brackets and re-tighten them.



1.2.8
Place the top panel (E) on the stove. If the flue pipe is connected at the top outlet, metal grate B must be lifted.

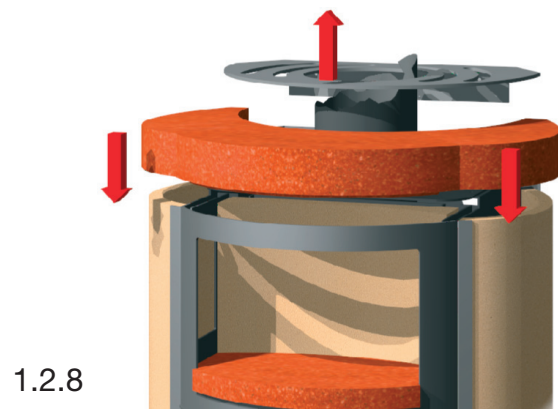

1.2.6
Insert the pack panel for the shelf from above and push backwards into its final position.



1.2.9
When metal grate B is back in place, the installation is complete.



2.10 Installing soapstone elements



1. Remove the lid.



2. Remove the top part of the box.



3. The soapstone elements are ready to be unpacked.



4.

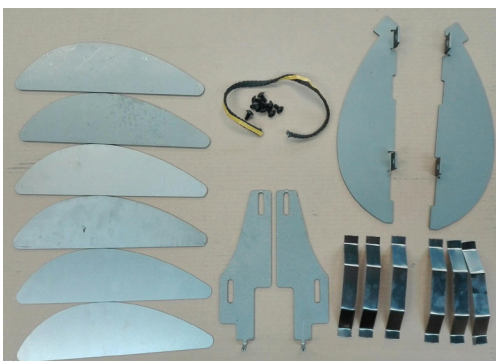

5. Parts to be installed



6.
The stove is ready
for installation of
the soapstone.



7. Attach the bottom side stone.



8. Place the side stone in the correct position.



9.
When the side stone is in place, install a spring
(6 provided) roughly at the middle of the stone.



10. Repeat this process with the second and third side stones.

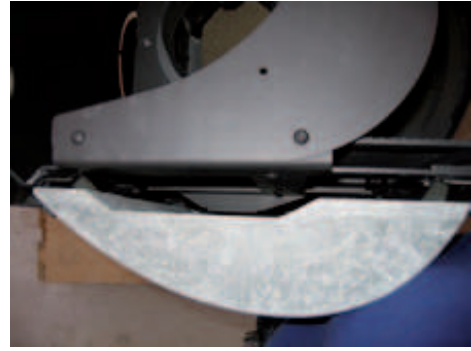

14. Correct position of the spring for the top stone.



11. Use a rubber mallet to gently adjust the sides so there are no gaps.

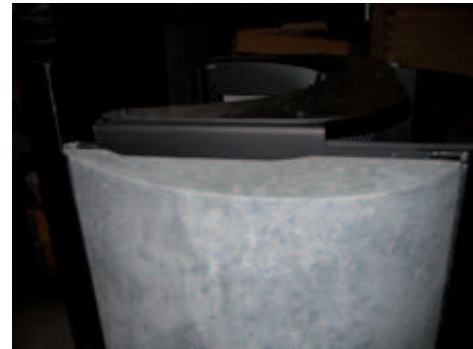

15. Watch the height on both sides when installing the side stones.



12. Install the top stone.



16. First side.



13. Install the spring for the top stone.



17. Both sides installed.



18. Insert the pack panel for the shelf from above and push carefully backwards into its final position.



22. Insert the horizontal stone at an angle and rotate it gently into place.



19.



23.



20. Before installing the horizontal stone, attach the sealing strip provided to the back.



24. Remove the rear screw in the top plate.



21. Protect the stones during installation.



25. Attach the two brackets supplied.

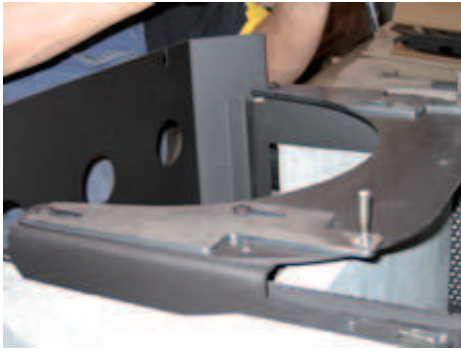

26. The pins should face forward so they fit the holes in the top soapstone element. The slotted holes allow for adjustment.



30. Adjust the top panel so that it is correctly positioned.

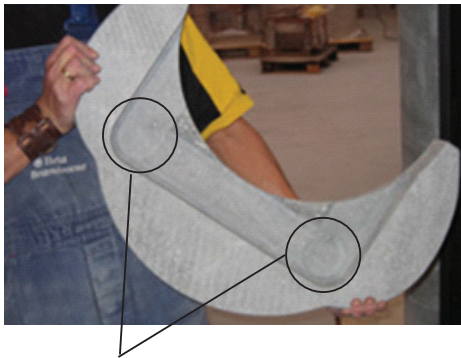

27. Take hold of the top panel as shown in photo.



31.



28. These two milled holes fit over the bracket just installed, holding the top panel in place.



32. When the top panel is in position, tighten these screws so that it cannot move.



29. Rear view of the installed top panel.



33. Install the ventilation top.



34. Place the ventilation top as shown.



35. Tighten the screws.



36. Loosen the screw before installing the vertical stone in the ash door.

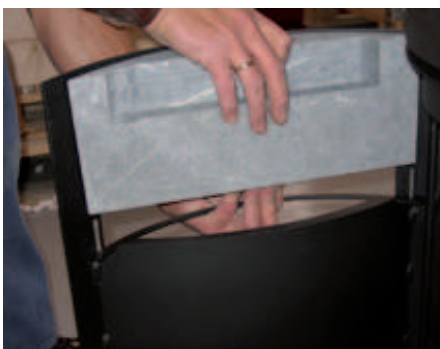

37. Install the stone.



38. Once the stone is in place, carefully re-tighten the screws so that the stone cannot move.



39. Place the base stone at an angle inside the ash door and rotate into position.



40. Installation of the Turin soapstone elements is complete.



Ecodesign
EU Declaration of Conformity

DoC Scan-Line 500 2354-2018

Product fiche



Manufacturer	Heta A/S
Address	Jupitervej 22, DK 7620 Lemvig
E-mail	heta@heta.dk
Website	www.heta.dk
Telephone	+45 9663 0600

Model identifier	Scan-Line 500, 510, 520, 520B, 550, 551, 560B, 560S, 590, Turin, Turin B, Napoli, 10-20-20B-30-30B, Tour 10-20-30, 40-40B-50-50B serie
-------------------------	--

The identified product described above is in conformity with:

The relevant EU harmonized regulations:

DIR 2009/125/EF
REG (EU) 2015/1185
REG (EU) 2015/1186
REG (EU) 2017/1369
REG (EU) 305/2011

The relevant harmonized standards

EN 16510-1-2022
EN 16510-2-1-2022

Characteristics when operating with the preferred fuel only

Heat output

Item	Symbol	Value/Unit
Nominal heat output	P_{nom}	6 kW
Minimum heat output	P_{min}	

Useful efficiency (NCV as received)

Useful efficiency at nominal heat output	$\eta_{th, nom}$	82%
Useful efficiency at minimum heat output	$\eta_{th, min}$	

Auxiliary electricity consumption

At nominal heat output	$e_{l, max}$	- kW
At minimum heat output	$e_{l, min}$	- kW
In standby mode	$e_{l, SB}$	- kW

Type of heat output/room temperature control

single stage heat output, no room temperature control	Yes
two or more manual stages, no room temperature control	No
with electronic room temperature control	No
with electronic room temperature control	No
with electronic room temperature control plus day timer	No
with electronic room temperature control plus week timer	No

Other control options

room temperature control, with presence detection	No
room temperature control, with open window detection	No
with distance control option	No

Notified body relevant to the assessment and verification of constancy of performance

Danish Technological Institute, DK-8000 Aarhus
No. 1235. Report no. 300-ELAB-2354-EN

Fuel	Preferred fuel	Other suitable fuel
Wood logs with moisture content $\leq 25\%$	Yes	No
Compressed wood with moisture content $< 12\%$	No	Yes
Other woody biomass	No	No
Non-woody biomass	No	No
Anthracite and dry steam coal	No	No
Hard coke	No	No
Low temperature coke	No	No
Bituminous coal	No	No
Lignite briquettes	No	No
Peat briquettes	No	No
Blended fossil fuel briquettes	No	No
Blended biomass and fossil fuel briquettes	No	No
Other blend of biomass and solid fuel	No	No

Emissions at nominal heat output	η_s %	mg/Nm ³ (13 % O ₂)			
		PM	OGC	CO	NO _x
		≥ 65	≤ 40	≤ 120	≤ 1500
	72	19	50	558	90

Technical documentation

Indirect heating functionality:	No
Direct heat output:	6 kW
Energy Efficiency Index (EEI):	EEI 109
Fluegas temperature at nominal heat output	T 243°C
Energy efficiency class	

Safety

Reaction to fire	A1
Test of fire safety in connection with the burning of wood	Approved
Distance to combustible materials Rear. Without insulation / with insulation Sides distance to combustible materials Furniture distance	Minimum distances in mm 150 350 1000

Signed on behalf the manufacturer of 20.11.2025



Jupitervej 22, DK-7620 Lemvig
TLF: +45 96 63 06 00
Martin Bach

The chimney sweep's signature Date _____

Signature _____